

## DATA SHEET | FIREMIKS<sup>®</sup> 800-1-2-3-PP-M (Handle)

### MOBILE PROPORTIONING SYSTEM WITH SELECTABLE 1%-2%-3% DOSING

Robust, mobile and easy proportioning system for firefighting, with working pressure up to 16 bar and flow up to 800 lpm. Extinguishing water drives the volumetric water motor, which in its turn drives the positive displacement dosing piston pump, that doses the correct amount of concentrate in the extinguishing water. No additional energy is needed, and the dosing is automatic - no requirement for calibration or pressure balancing. Dosing is also immediate which allows quickly opening and closing the nozzles (pulsing).

FIREMIKS is equipped with a Manual air relief to speed up priming of dosing pump (alternatively Automatic air relief valve). Flushing of dosing pump is done automatically when the concentrate inlet is closed with Selector valve Dosing/Flushing (no 4 on Flow chart).

Easy to select 1%, 2% and 3% with two Selector valves (no 9 on Flow chart) placed on dosing pump, even while unit is in action.

Complete with Handle and bottom bracket (optional with lockable wheels), separate suction pipe and with a separate Y-filter to protect from foreign particles entering the water motor. Version with sturdy Stainless-Steel Frame also available.

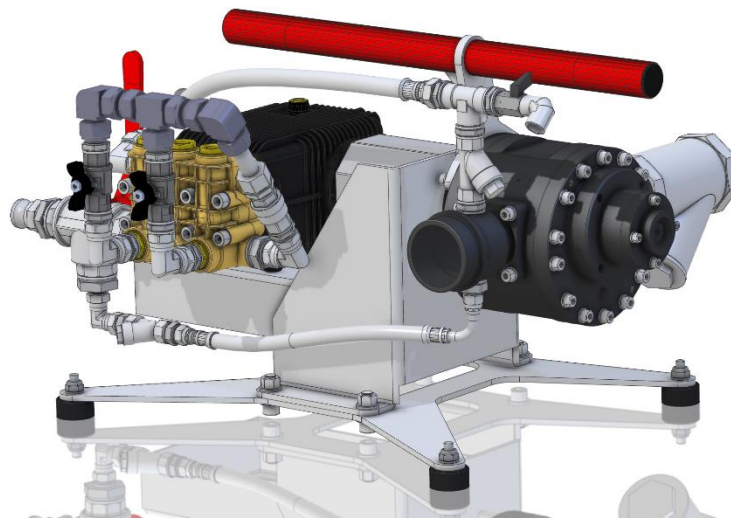

### TECHNICAL DATA

Max water flow rate @ rpm:	800 lpm (211 US gpm) @ 1055 rpm
Min water flow rate @ 8 bar 1-20 cP*:	180 lpm (48 US gpm)
Min water flow rate @ 4 bar 1-20 cP*:	135 lpm (36 US gpm)
Viscosity range:**	1-1800/3600 cP (Brookfield #4 60/30rpm)
Dosing rate:***	Selectable 1-2-3%
Max inlet operating pressure:	16 bar (232 psi)
Factory tested pressure:	24 bar (350 psi)
Suction height:	0 meters (0 ft) Gravity feed (Up to 1 meter at full flow)
Operation temperature:	1°C to 55 °C (34°F to 131°F)
Storage temperature, dry condition:	-30°C to 55°C (-22° to 131°F)
Connections water motor G (ISO 228-1) male:	G 2 ½" - DN 65 – Couplings in customers choice available
Connection pump:	G 1" – DN 25 - Equipped with suction pipe

\* Notes on minimum flow:

- Minimum flow rate is the flow where dosing reaches 3%. (3% setting)
- Minimum flow changes depending on system pressure and viscosity properties of the concentrate and design of the suction line. See Instruction Manual.
- Below min flow, there is still dosing if the unit is rotating.
- Once min flow is reached in a typical application, usually dosing is no longer pressure sensitive at higher flows.

\*\*Consult with Firemiks AB for higher viscosities

\*\*\* Dosing tolerance 1% to 1,3%, 2% to 2,6% and 3% to 3,9% according EN 13565, NFPA 11 and FM 5130.

## MATERIALS

FIREMIKS Aluminium – For fresh water/salt water occasional use		FIREMIKS Bronze – For saltwater/offshore	
Water motor:	Alu AA 6082/7075-T6, (housing / rotor) Hard-anodized and PTFE-coated, Stainless steel AISI 316 (fasteners), PET (vanes), NBR (O-rings).	Water motor:	Al-Ni-Bronze JM7 (C95500) (housing / rotor), Stainless Steel AISI 316 (fasteners), PET (vanes), NBR (O-rings)
Dosing pump:	Wetted: Brass (head), ceramics, NBR (seals), stainless steel. Other: aluminium (body), hardened steel with corrosion protection (crankshaft), AISI 316 Fasteners	Dosing pump:	Wetted: Brass (head), ceramics, NBR (seals), stainless steel. Other: aluminium (body), hardened steel with corrosion protection (crankshaft), AISI 316 Fasteners
Flexible hoses:	High grade stainless steel + PTFE	Flexible hoses:	High grade stainless steel + PTFE
Fittings:	Stainless steel AISI 316L	Fittings:	Stainless steel AISI 316L
Ball valves:	Nickel-plated brass, brass, PTFE, SS	Ball valves:	Stainless Steel AISI 316, PTFE
Frame	Stainless steel	Frame	Stainless steel

**Note: water motor made from Stainless steel AISI 316L (housing/rotor) also available, remaining spec same as bronze.**

## APPROXIMATE DIMENSIONS AND WEIGHT

Overall dim. L x W x H mm	760 x 600 x 410
Weight Aluminium:	49 kg
Weight Bronze or Stainless steel:	69 kg

Actual dimensions and weight depending on optional equipment.

## PRESSURE LOSS TABLE (@ 8 bar system pressure)

Flow	Pressure loss
135 lpm	0,8 bar
200 lpm	1,0 bar
400 lpm	1,2 bar
600 lpm	1,7 bar
800 lpm	2,3 bar

Pressure loss will vary slightly up to ±0,3bar, depending on system pressure and concentrate (lower with lubricating concentrates).

## PRODUCT NO

Aluminum:	800-1-2-3-PP-M-ALU (Handle)
Bronze:	800-1-2-3-PP-M-BRZ (Handle)
Stainless steel:	800-1-2-3-PP-M-SS (Handle)

## PRINCIPLE FLOW CHART

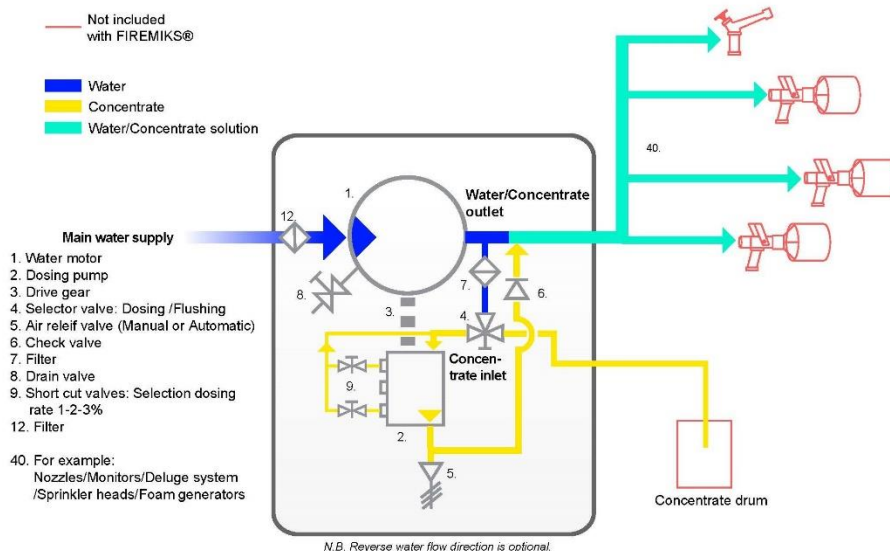

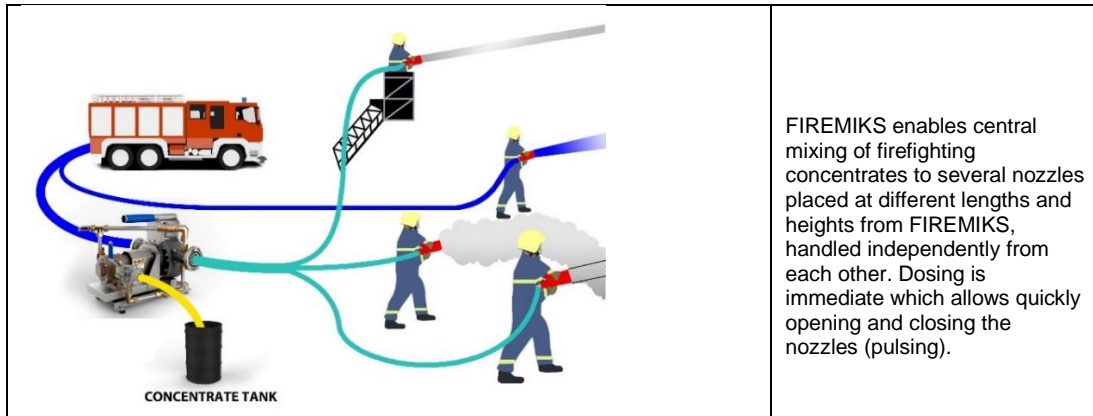
**ONE FIREMIKS – SEVERAL NOZZLES**

FIREMIKS enables central mixing of firefighting concentrates to several nozzles placed at different lengths and heights from FIREMIKS, handled independently from each other. Dosing is immediate which allows quickly opening and closing the nozzles (pulsing).

**RECOMMENDED SPARE PARTS FOR 2 – 5 YEARS**

<u>Water motor parts</u>	<u>Dosing pump parts</u>	<u>Complete unit parts</u>
1.10 Set of vane plates (5 pcs)	2.10 Water seals and plunger kit	3.10 Automatic Air relief valve
1.20 Set of Mechanical Seals (2 pcs)	2.20 In/Out valve kit	(3.11 Manual Air relief valve)
1.30 Set of Ball Bearings (2 pcs)		3.20 Check valve
1.40 Set of O-rings (6 pcs)		3.40 Filter flushing line
1.45 Set of Gable inserts (2 pcs)		

*Always mention the serial number of the units concerned when ordering Spare parts.*

**OPTIONAL FEATURES / ITEMS**

<u>Features / Items</u>	<u>Description</u>
Reversed water flow direction (right to left)	Standard flow direction is from left to right seen from pump side.
High-grade stainless-steel ball valves	Replacing brass valves (Already standard on Bronze water motor version and valves with iso 5211 interface)
Alternative couplings for water motor	The unit can be delivered with 2,5" hose couplings in customers choice. Flanges (ANSI, DIN), Storz couplings, etc.
Certifications / Factory Acceptance tested (FAT)	Each unit can be type tested according to applicable parts of NFPA 11 or EN 13565, Factory Acceptance tested (FAT) or delivery inspected by <i>DNV-GL</i> or <i>Bureau Veritas</i> .
Material certificates EN 10204	Depending on availability, material certificates for the water motor materials and some other parts can be provided if specified when ordered.

**APPROXIMATE GROSS WEIGHT AND DIMENSIONS OF GOODS**

The unit is delivered on a EUR pallet, with instruction manual in printed form.

Overall dim of packaging.		
L x W x H cm:		60 x 80 x 75
Weight of packaged goods:	Aluminium	79 kg
	Bronze and Stainless steel	100 kg

*Note! Weight and dimensions specified here serves only as a guideline, and may vary depending on if you choose different optional equipment. Correct weight and dimension of the goods are given before delivery.*

**FIREMIKS® is a registered trademark owned by Firemiks AB in Sweden.**

Firemiks AB is SS-EN ISO-9001:2015 certified by Bureau Veritas, cert.no SE006796-1.

Scope of supply: Development, production and sales of water motor driven dosing systems for firefighting.

CE FIREMIKS® is CE-marked and production is made according to European Directive 2006/42/EC.

Conforms to applicable parts of NFPA 11 and NFPA 1901. 

We reserve the right to make changes in the specifications without prior notice.

