



INSTRUCTION MANUAL

FIREMIKS – PP PISTON PUMP TYPE MOBILE MODEL

including Installed fixed or semi-fixed on a Fire truck
or Foam trailer

Original English version

Firemiks AB | Sweden | VAT.no SE 556799500501
Phone +46-8-551 196 10 | info@firemiks.com | www.firemiks.com
ISO 9001 Certified by Bureau Veritas

INSTRUCTION MANUAL | FIREMIKS[®] - PP PISTON PUMP TYPE - MOBILE MODEL

This instruction manual applies to following models:

Model	Fixed admixture rate			
180-...-PP-M	0,5%	1%	2%	3%
450-...-PP-M	0,5%	1%	2%	3%
600-...-PP-M	0,5%	1%	2%	3%
800-...-PP-M	0,5%	1%	2%	3%
1000-...-PP-M	0,5%	1%	2%	3%
1200-...-PP-M	0,5%	1%	2%	3%
1800-...-PP-M	0,5%	1%	2%	3%
2400-...-PP-M	0,5%	1%	2%	3%

Model	Selectable admixture rate		
180-...-PP-M	0,5%-1%	1%-2%-3%	
450-...-PP-M	0,3%-0,6%-1%	1%-2%-3%	
600-...-PP-M	0,3%-0,6%-1%	1%-2%-3%	0,5%-1%-3%
800-...-PP-M	0,3%-0,6%-1%	1%-2%-3%	
1000-...-PP-M	0,3%-0,6%-1%	1%-2%-3%	0,5%-1%-3%
1200-...-PP-M	0,3%-0,6%-1%	1%-2%-3%	
1800-...-PP-M	0,3%-0,6%-1%	1%-2%-3%	
2400-...-PP-M	0,3%-0,6%-1%	1%-2%-3%	0,5%-1%-3%

With automatic flushing of concentrate pump when concentrate inlet is closed.

TABLE OF CONTENTS

1	EC Declaration of conformity	3
2	Read this first!	4
3	General description	6
4	Set-up before use	10
5	Check before start.	26
6	Operation	28
7	Maintenance	33
8	Troubleshooting	36
9	Spare parts	39
10	Tables Tightening torque	42
11	Material recycling guide	43
12	Overview and repetition of paragraphs essential for safety	44

Appendix 1 – Data sheet

Appendix 2 – Dimensional drawing

Appendix 3 – Orgalime S2012; General conditions for the supply of mechanical, electrical and electronic products.

Appendix 4- Quick Instruction

1 EC Declaration of conformity



According to European Directive 2006/42/EC

Manufacturer:

Firemiks AB

Mätarvägen 9A

SE-196 37 STOCKHOLM, Sweden

Tel: +46-8-551 196 10

www.firemiks.com, info@firemiks.com

Model	Fixed admixture rate			
180-...-PP-M	0,5%	1%	2%	3%
450-...-PP-M	0,5%	1%	2%	3%
600-...-PP-M	0,5%	1%	2%	3%
800-...-PP-M	0,5%	1%	2%	3%
1000-...-PP-M	0,5%	1%	2%	3%
1200-...-PP-M	0,5%	1%	2%	3%
1800-...-PP-M	0,5%	1%	2%	3%
2400-...-PP-M	0,5%	1%	2%	3%

Model	Selectable admixture rate		
180-...-PP-M	0,5%-1%	1%-2%-3%	
450-...-PP-M	0,3%-0,6%-1%	1%-2%-3%	
600-...-PP-M	0,3%-0,6%-1%	1%-2%-3%	0,5%-1%-3%
800-...-PP-M	0,3%-0,6%-1%	1%-2%-3%	
1000-...-PP-M	0,3%-0,6%-1%	1%-2%-3%	0,5%-1%-3%
1200-...-PP-M	0,3%-0,6%-1%	1%-2%-3%	
1800-...-PP-M	0,3%-0,6%-1%	1%-2%-3%	
2400-...-PP-M	0,3%-0,6%-1%	1%-2%-3%	0,5%-1%-3%

With automatic flushing of concentrate pump when concentrate inlet is closed.

The manufacturer **Firemiks AB** declares that the above products conform to European Directive 2006/42/EC and are designed according to the following standards: SS-EN ISO 12100-1 and 12100-2.

The product is manufactured under a production control system, which guarantees conformity between the manufactured product and technical data.

Installation, connection, maintenance and usage should take place in accordance with the products instructions and design, which are described in the manufacturer's technical documentation as well as according to practice. In accordance with the EC Declaration of conformity, the product must not be modified without the manufacturer's permission. If this occurs, this documented EC Declaration ceases to apply and the products owner is considered to be the manufacturer and must verify and draw up an addendum to the EC Declaration and file technical data for the inspection authority.

2024-12-12

Firemiks AB

Mikael Aredal, Managing Director

2 Read this first!

- 2.1 Check at the reception of the goods that the delivery is complete and without damages. Any discrepancies and damages should be informed to the transport company and the supplier immediately.
- 2.2 For your own safety is it very important that you read all information in this Instruction Manual before you install and start using this equipment, especially the comprehensive section 12 *Overview and repetition of paragraphs essential for safety*. We want to point out that the user is responsible that the safety instructions are followed strictly. See also the **WARNING SIGNS** on the unit.



- 2.3 The FIREMIKS unit must be used following the user and safety instructions given in this manual. As the user, you are responsible that the safety and operating instructions of any other systems, environment or container where the FIREMIKS unit is used in conjunction with, are followed.
- 2.4 Inform yourself about the fire-fighting concentrate (additive) producer's instructions about leakages and spillage. Observe especially the directions about spillage on hands and eyes. Assure yourself also that local and national laws and regulations are followed concerning environmental protections regarding waste leakage, spillage and tests with the fire-fighting liquid. Firemiks AB encourages any users of their products to do their utmost to prevent unnecessary spillage of any concentrate on and into the ground and groundwater if there is a possibility of a negative impact.
- 2.5 The unit must only be used under the working conditions specified in this instruction. Any deviation from that requires the producer's permission.
- 2.6 The user is responsible to carry out the instructions according to chapter 7 *Maintenance*.
- 2.7 The unit is designed to dose fire-fighting liquids (=concentrate) in fire-fighting main water line. The FIREMIKS is designed to be durable and to serve in fire emergencies. It is not intended for continuous use 24/7. For all other applications other than firefighting, contact must be made with Firemiks AB for an approval, if possible to give such.

- 2.8 **The unit itself makes noise when operating.** Be sure to wear ear protection when you are continuously exposed to high noise levels.

Models	Noise level dB (A) at max flow
180	78 ± 2
450	81 ± 2
800	84 ± 2
1200-2400	90 ± 2

- 2.9 **The maximum operating pressure of the unit is 16 bar. If there is a failure of the unit or the surrounding installation, powerful water jets may occur. Always wear eye protection!**
- 2.10 **If you think information is missing in this Instruction Manual, please contact your distributor or Firemiks AB. This is particularly important if the user believes that there exist risks that are not covered in this manual.**
- 2.11 **If the unit is transferred to a third party this instruction manual must follow the unit.**
- 2.12 **Warranty terms: For the warranty of 2 years from delivery from our workshop to be valid, all instructions in this manual must have been followed carefully. Full warranty terms are stated in Appendix 3 - *Orgalime S2012; General conditions for the supply of mechanical, electrical and electronic products*, unless otherwise agreed in writing.**

3 General description

FIREMIKS® is a dosing system used primarily for different types firefighting, although other applications are possible. These systems are referred to as **Water Motor Driven Variable Viscosity Proportioners** as they are powered by the main extinguishing water flow, and they can correctly proportion a wide range of viscosity of the concentrate.

The extinguishing water flow from a main water pump or source goes through the FIREMIKS water motor. The power of the water flow generates a circular rotor motion in the FIREMIKS water motor, which is transferred through an internal drive or an external drive gear to the FIREMIKS concentrate pump. The concentrate pump pumps concentrate from an atmospheric tank into the water motor outlet creating the water/concentrate mixture.

FIREMIKS is not a water pump, it is a dosing system is driven solely by the existing extinguishing water flow - no additional energy source is required. The volumetric water motor acts both as a 'flow meter' to have the pump turn at the appropriate speed to dose correctly, and a power-take-off to power the pump. As such dosing is automatically adjusted from the amount of water that goes through the FIREMIKS, within the dosing limits as presented in your unit's data sheet.

Likewise, to stop the FIREMIKS from rotating, one must stop the water flow through it.

Designed and developed by Firemiks AB.

- 3.1 **Dosing system for Mobile use**, with suction pipe to pick-up concentrate from a separate drum, at the same level as the unit or with gravity feed of the concentrate liquid. Equipped with an Automatic air relief valve, alternatively a Manual air relief valve, to facilitate priming. Flushing of the concentrate pump is done automatically when the concentrate inlet is closed with Selector valve Dosing/Flushing (*No 4 on Flow chart*).

3.2 Illustration of functioning principle FIREMIKS - PP

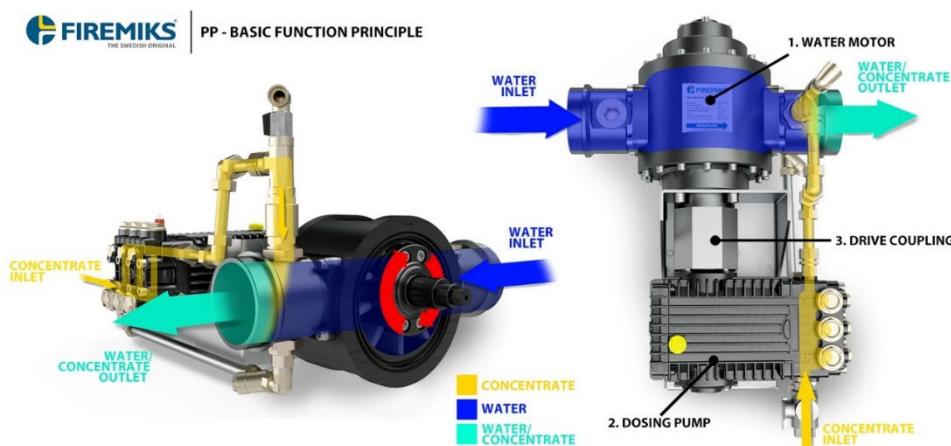

3.3 Overview main parts Mobile model (generic illustration)

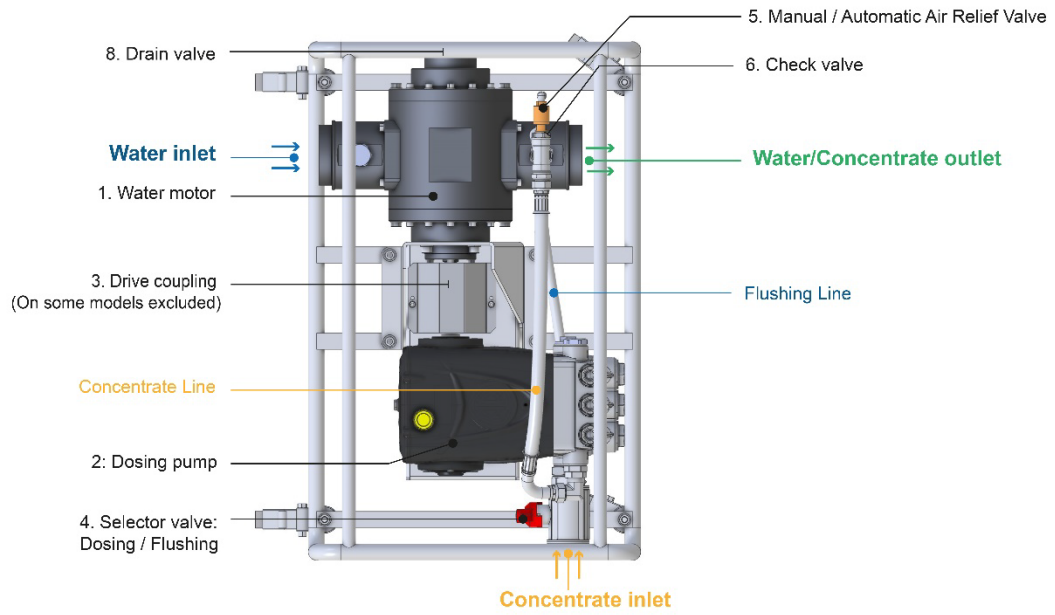

3.4 Principle flow chart for Mobile model

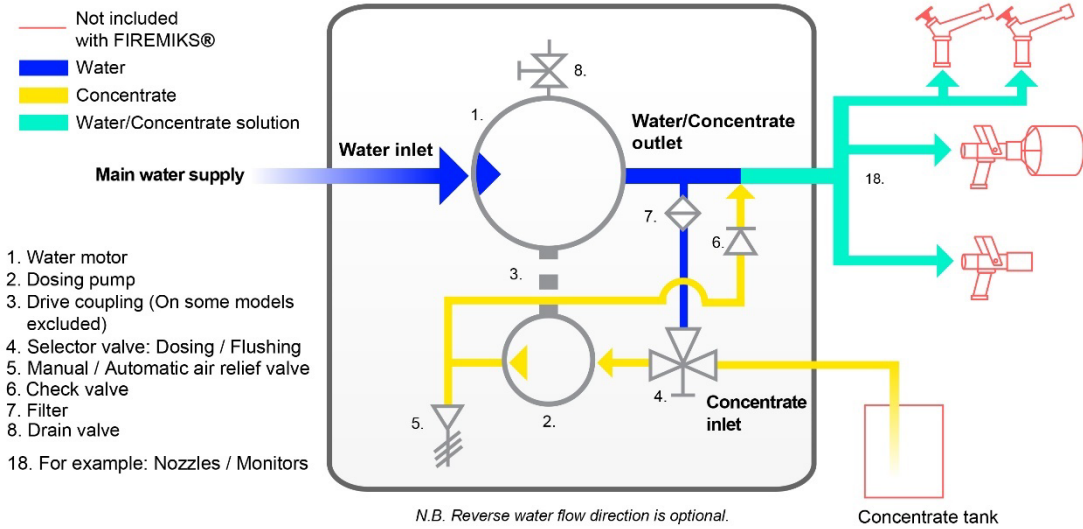

3.5 Flow arrows



The arrows are situated on respectively dosing line and flushing line.

3.6 Key properties of the Mobile FIREMIKS PP-M

In the following chapters the use and maintenance of the FIREMIKS will be discussed in detail. In order to quickly become familiar with the unit, here we give a **quick preview** of the key properties that are important for a trouble-free use:

- The FIREMIKS is designed for use with a clean water supply only, always use a strainer or filter if there is any possibility for water polluted with solid particles, sand, stones, ice etc.
- The FIREMIKS is designed to be durable and to serve in fire emergencies. These models has passed endurance tests for 24 hours at each units maximum flow, but is not intended to be used continuously 24/7. Contact your seller to see if applications for longer use are possible.
- Before connecting the FIREMIKS, all hoses and piping before the unit must be flushed thoroughly.
- FIREMIKS is designed to be used with water temperature up to 55 degrees C.
- Foam concentrate supply to the FIREMIKS is preferred to be with gravity feed (inlet pressure > atmospheric pressure), or at the same level as the unit.
- Place the FIREMIKS as close to the Foam concentrate drum/container as practically possible.
- Avoid overflow (exceeding rated flow) when using the FIREMIKS. Always match the FIREMIKS flowrate to the total possible flow from connected nozzle(s) and other discharge devices. Repeated overflow of the unit may lead to excessive wear and ultimately failure of the unit.
- The FIREMIKS concentrate pump should not run dry. When the foam concentrate container is empty, swiftly switch to flushing with Selector valve Dosing/Flushing (No 4 on Flow chart) or stop water flow altogether.
- The FIREMIKS should be operated/rotated, by water or by hand, at least once a month to prevent the seals in the unit from seizing.
- For saltwater use, do not allow salt water to dry inside the unit as salt crystallization can stop the FIREMIKS from rotating.
- The FIREMIKS must be flushed with sweet water using the in-built flushing position of the Selector valve Dosing/Flushing (No 4 on Flow chart). Otherwise concentrate can dry inside the unit and stop it from functioning.

The above is to give a general idea and does not replace reading this whole instruction manual. In case of doubt, always refer to the chapters that follow.

4 Set-up before use

4.1 Storage

- 4.1.1 Respect the temperature limits specified in the Data Sheets. Standard is 1 to 55 °C.

The unit should preferably be stored and used in a frost and ice free environment. If this is not possible to store the unit frost-free, it is important to drain the unit completely before frost season.

- 4.1.2 If the unit/shipping package is stored in a contaminated environment where there is a risk that dirt, dust, sand or other foreign particles can enter the unit (flooding, sandstorm), make sure to provide additional protection to the unit/shipping packaging or move it to a more secure place. Attempting to run the unit with dirt lodged inside the water motor and/or pump may permanently damage it.

- 4.1.3 Protection caps: Let the plastic protection caps and plugs remain on the unit until it is to be used or provide suitable covers to the connections used on the unit.

4.2 Weight and lifting:

- 4.2.1 Weight is stated on the Product plate on unit and on respective Data sheet.

- 4.2.2 DO NOT lift the unit using the piping or hoses, always lift the unit using the frame or carrying handle!

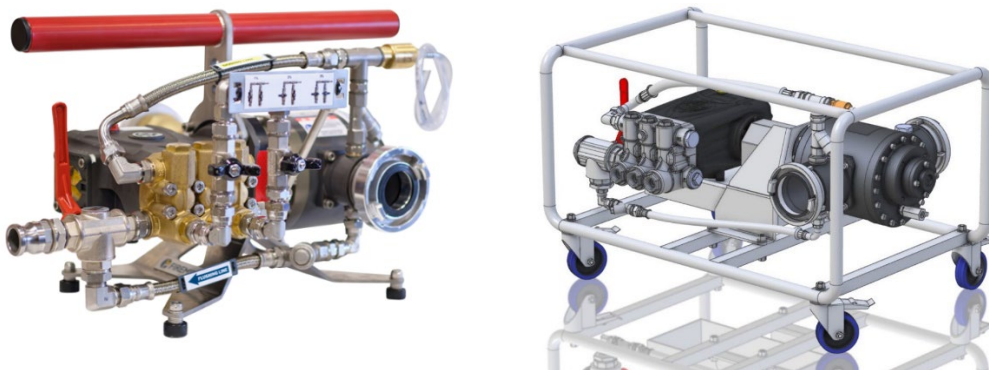

4.3 Requirements for the system around the FIREMIKS

- 4.3.1 **FIREMIKS is designed to operate with clean water.** Water must be free from sand, gravel and other debris that may wear out the volumetric water motor quickly. In most cases the FIREMIKS can cope with occasional instances of isolated foreign objects up to 2 mm size. If there is a risk of particles entering the FIREMIKS or when polluted or contaminated water is used, the hoses and/or piping system must be designed so that there is place for a suitable filter or strainer where this pollution can be collected **fully**, placed **before** (upstream of) the FIREMIKS. All Mobile models are supplied with strainer to be fitted on water motor inlet. **We refuse any responsibility for blockage or damage of the water motor by any foreign objects in the water, whatever their size.** Please contact us if you need further guidance in this subject.



- 4.3.2 **Note! Hoses and pipings must be flushed out thoroughly before connecting the FIREMIKS in the system.** (There are often foreign particles left). Take care so other foreign particles do not come into the unit before use. Keep the protection caps and plugs on the unit on as long as possible. Also take note of the requirements on clean water for any discharge devices mounted downstream of the FIREMIKS.



- 4.3.3 For mobile applications with hoses, no minimum length of straight hoses for the water supply before or after the FIREMIKS is required, although a sharp bend of hoses just before the FIREMIKS unit may move the unit unintentionally. It is also recommended to add a couple of meters of single hose before a divider is installed to ensure that concentrate is mixed thoroughly before divided into two or more streams.

- 4.3.3.1 For fixed or semi fixed installations of mobile units, for vertical* bends, no minimum length of straight piping at the inlet or outlet of the FIREMIKS is necessary. For horizontal* bends, minimum ten pipe diameters before the inlet and five after the outlet are recommended. Minimum five pipe diameters before the inlet and two after the outlet are required. * horizontal and vertical referring to a normally installed Firemiks with horizontal flow direction.

- 4.3.4 **Maximum flow** in the system must be checked with a flow meter if water source pumping capacity is higher than the max flow of the FIREMIKS. If there is a risk that the water flow could exceed the stated max. flow, there should be some kind of flow limiter placed before the unit. **Always match the FIREMIKS flowrate to be equal or higher than the total possible flow from connected nozzle(s) and other discharge devices. Repeatedly overflow of the unit may lead to excessive wear and ultimately failure of the unit.**



- 4.3.5 **Overspeeding at start-up.** Even if the main water pump has a capacity equal or below the max flow capacity of the FIREMIKS, over-speeding can happen at the start if the hoses are empty and the flow-limiting parts/nozzles are located after the unit. This risk for over-speeding could be minimized by gently (with low pressure) filling the hoses up to the nozzles first, if possible by partly opening the nozzles.

4.3.6 **Measuring unit rpm as a measure of flow and overspeed.** It is possible to measure the rpm of the FIREMIKS with a mechanical tachometer on the water motor axle to get an indication of the water flow through it and to make sure it does not overspeed. The unit rpm is directly related to the main water flow through the unit. Max flow rpm is in the unit datasheet. Contact your distributor or Firemiks AB if more information is needed about rpm of your specific unit.

4.3.7 In the case that the pressure capacity of the pumping system is higher than the maximum rated pressure of the FIREMIKS unit, it is recommended that a pressure-relief valve is installed in the main system.



4.3.8 If the unit is intended to operate for an extended period of time (more than 10 minutes) with extinguishing water only, **it is better to use a separate hose or a by-pass around the FIREMIKS system** to avoid unnecessary wear of the volumetric water motor.



4.3.9 **Note! As in all safety-related installations, there should always be a back-up plan. Never rely on the water flow through the FIREMIKS as the only source for fire-fighting water.**

4.4 Concentrates

4.4.1 The FIREMIKS can be used with all common foam liquids/fire-fighting additives. As for example synthetic AFFF, AFFF-AR and protein-based FP, FFFP and FFFP-AR incl new SFFF Fluorine free concentrates. The general viscosity range is from 1 cP up to around 4000-5000 cP (Brookfield #4 30rpm). Should there be any questions about different additives, please contact us and state additive type and brand. **Note! Minimum water flow rate to achieve correct dosing varies with viscosity properties and system pressure, higher viscosity and higher system pressure increases minimum flow.**

4.4.2 For Newtonian concentrates with higher viscosities (> 100 cP), and Non-newtonian concentrates above around 4000-5000 cP (Brookfield #4 30rpm) we normally recommend the GP (Gear Pump) type FIREMIKS.

4.4.3 This FIREMIKS type is NOT suitable for Gel Forming additives. Contact FIREMIKS AB for a special version of the FIREMIKS that can handle these additives.

4.5 Concentrate delivery to the unit.

- 4.5.1 **The supply of concentrate to the FIREMIKS unit is preferred to be done with gravity feed.** Gravity feed means that the lowest possible concentrate level in the tank is higher than the inlet of the concentrate pump on the FIREMIKS in such a way that it delivers the required concentrate flow to the pump inlet by gravity alone.

In practice, this means placing the foam concentrate tank/drum higher than the FIREMIKS unit. In most cases the FIREMIKS unit will be on the ground and the Foam concentrate tank will be on a vehicle or trailer and that is sufficient. If the container is placed on the same level as the unit (i.e. on the ground), this will in most cases work but it is not the preferred scenario.

4.5.2 Design of the concentrate feed line.

Always aim to have as short and easy flowing foam concentrate feed to the FIREMIKS as possible as it is critical for reliable performance of the FIREMIKS.

The mobile unit comes delivered with a suction pipe for use with a small foam concentrate container/drum. For more continuous use on a Fire truck or Foam trailer, a dedicated concentrate feed line should be designed to connect to the chosen type of concentrate tank with a custom design as below:

- Place the concentrate tank and FIREMIKS as close together as is practically possible. The delivered suction hose is short for this reason.
- Foam concentrate is supplied to the Selector valve Dosing/Flushing (*No. 4 on Flow chart*) on the concentrate pump inlet.
- The internal diameter on concentrate feed system including any valves etc. must have one size larger diameter as the inlet of the Selector valve Dosing / Flushing (*No. 4 on Flow chart*), *see also Appendix 1 Data sheet and Appendix 2, Dimensional Drawing*. Additional valves are discouraged as they increase the risk of operator error and could cause dry running (see 4.13) if a valve is unintentionally closed.
- Avoid sharp 90-degree bends and keep the concentrate feed line as free as possible from other flow restrictions (bends, bottom valves, unnecessary filters).
- **Avoid elevation changes in the line where air bubbles may stagnate and cause head losses and cavitation.**



- If there is any risk of contamination of the concentrate, the concentrate feed line must be equipped with a free-flowing filter (pressure drop <0,05bar) with mesh size 300 µm or less positioned as close as possible to the pump feed attachment.
- It is advisable to use a transparent concentrate feed tube to make it easier to see when/if the concentrate feed hose is completely filled with the concentrate. This also minimizes the risk for tensions from a concentrate pipe to be transferred to the concentrate pump.
- It is very important that there are no air leakages in the concentrate feed line anywhere between the tank/drum and the concentrate pump when using suction. Any air leakage may be invisible but will cause the concentrate to not flow.

4.6 Water connections

- 4.6.1 **The main water flow must be in the direction shown by the arrow on the upper side of the water motor** (Note! The direction of rotation of the rotor/drive shaft is reversed compared with the direction of the water flow arrow). The unit can optionally be configured with the water flow in the opposite direction. See also Dimensional Drawing for each model.



4.6.2 Make sure you have the correct material and adaptors to connect to the water motor and couplings in your choice. Connection type on water motor is found in the Dimensional Drawing and Data sheet. Hoses should preferably be of similar dimension or larger as the water connections on the unit.

4.6.3 The water motor inlet and outlet are not infinitely strong, and measures should be taken to limit the forces and tensions on it made by the hoses. Common sense applies. E.g. do not step on the hoses close to the unit (especially for small units 180-1200) **and connect one single hose after the unit before a heavy divider for several hoses is connected.**



4.7 Unit preparations and orientation

4.7.1 **Once the unit is to be put in use, remove the plastic plug from the top of the concentrate pump, and replace it with the supplied oil dipstick.** The oil dipstick is a secondary way to check the oil level and is also vented to remove any pressure from heat from the crank case during operation.



4.7.2 The unit must be placed horizontally during storage and use. **The plunger pump's vented dip stick will leak oil** if the unit is stored sideways or upside down. During use, the unit must be placed horizontally on its feet to allow for crank shaft lubrication. Angles up to 15 degrees from horizontal are allowed for continuous use.

4.7.3 The unit should preferably be set-up and used in a frost-free environment. If this is not possible it is important to drain the unit completely after use.

- 4.7.4 It should not be exposed to higher temperature than 55 degrees C, even when the unit is not in use. This is both valid for the ambient temperature and for the water temperature.



Note! Be observant for direct solar radiation that can heat up the unit above 55 degrees C, in these circumstances be sure to place the unit in the shadow. Contact us if higher temperature tolerances, above 55 degree C, are needed.

If the unit was exposed to more than 55°C, contact your distributor or FIREMIKS AB on what to do, most likely we will recommend replacing the water motor vanes.

- 4.7.5 If the unit has been contaminated during storage, see also 4.1, make sure to carefully clean the inside of the unit before attempting to use the unit (let it rotate and pump). If contamination is especially aggravated and/or temperature limits have been exceeded, please contact your distributor or FIREMIKS AB on how to proceed.

4.8 Valve maneuvering on the FIREMIKS unit.

For the operating instruction of *when* the valves must be operated, refer to section 6.1. This section considers the function of the valves.

4.8.1 Selector valve Dosing / Flushing

The unit comes equipped with a manual selector valve for Dosing or Flushing.

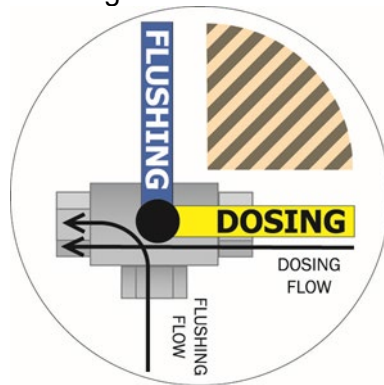

Warning: Always make a fast and determined switch with the Selector valve Dosing / Flushing (No. 4 on Flow chart), leaving it only at its end positions.

Otherwise, if the selector valve is left between its two end positions, the valve may be open for both flushing and dosing and thus pressurized flushing water can enter the suction line and pollute or even overflow the concentrate tank/drum.



Flushing



Dosing

4.8.2 Automatic Air relief valve

If the unit is equipped with **Automatic Air relief valve** this valve does not need any handling. It stays open below 1 bar pump pressure. When dosing pump is primed the air is released from the suction line through this valve. When dosing pump is filled with concentrate and pump can start to create a pressure above 1 Bar this valve is automatically closed. Below 1 bar the Automatic Air relief valve may leak some concentrate until it closes.

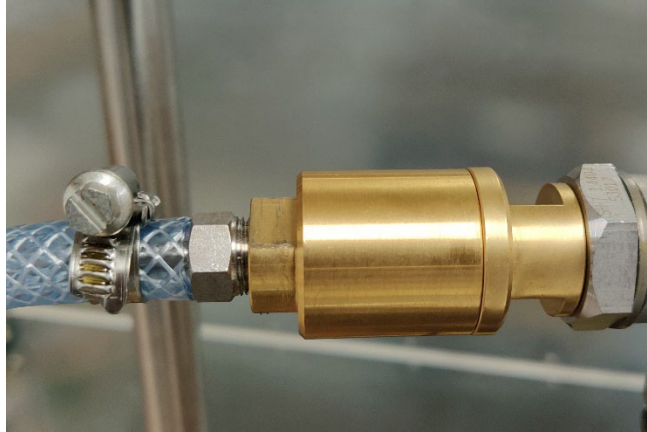

Automatic Air relief valve

4.8.3 Manual Air relief valve

If the unit is equipped with **Manual Air relief valve** should this valve only be opened when the Dosing pump is primed, to ensure that all air is let out of the suction line. When concentrate is pouring out of this valve it should be shut-off and remained closed during operation. You may need to repeat this action if air enters suction line for any reason.

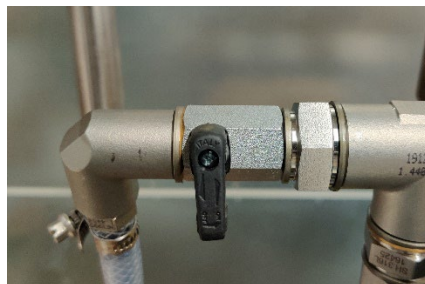

Manual Air relief valve **Closed**

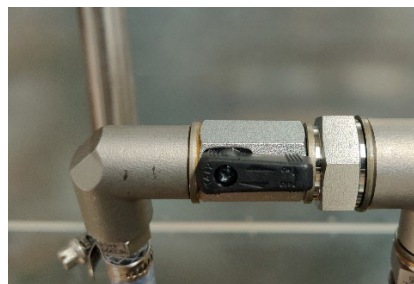

Manual Air relief valve **Open**

When the FIREMIKS is pressurized by the connected water hoses but there is no flow, the manual air relief valve can also be used to flush the pump from concentrate by using the flushing position and opening the manual air relief valve where the concentrate inside the pump will be discharged.

4.8.4 Drain Valve

All units, except the smallest 180 and 450 sizes, are equipped with a Drain valve. This valve is used to drain the unit from water for maintenance or storage. The unit must be completely drained from water if it is to be stored in freezing conditions. Drain valve should be closed in regular operation.



Drain valve **Closed**



Drain valve **Open**

The small mobile 180 and 450 units can easily be tilted up to 45 degrees to let excessive water drain from the unit. Do not tilt too much though as the pump oil may then leak from the vented dip stick.

4.8.5 Filter

The flushing line is equipped with a traditional Y-strainer type filter so that no debris may enter the pump during flushing.

On this filter type, the system must be made pressure free before opening the filter cap.



Opened filter



4.9 Selectable admixture 1%-2%-3%, 0,3%-0,6%-1%



4.9.1 Units can optionally be specified with a selectable admixture by shortcutting one or two or three of the three pistons/plungers. If the unit is equipped with this functionality this will show in its designation, e.g. a FIREMIKS 1200-3-PP then becomes a FIREMIKS 1200-1-2-3-PP unit.

For the 1%-2%-3% models equipped with a 3% pump, opening one shortcut valve reduces the admixture with a $1/3$ (= 2% dosing), opening both shortcut valves reduces it with $2/3$ (= 1% dosing). **For the shortcuts to work properly the unit must be running in a pressurized installation.** Testing with the FIREMIKS water outlet open to the atmosphere will not result in a significant reduced admixture.

Selector valve for 1%-2%-3% unit:

1%	2%	3%
		
OPEN OPEN	CLOSED OPEN	BOTH CLOSED

4.9.2 The same applies for the 0,3%-0,6%-1% models equipped with a 1% pump. Opening one shortcut valve reduces the admixture with $1/3$ (= 0,6% dosing), opening both shortcut valves reduces it with $2/3$ (= 0,3% dosing).

Flow chart 1%-2%-3% (0,3%-0,6%-1%)

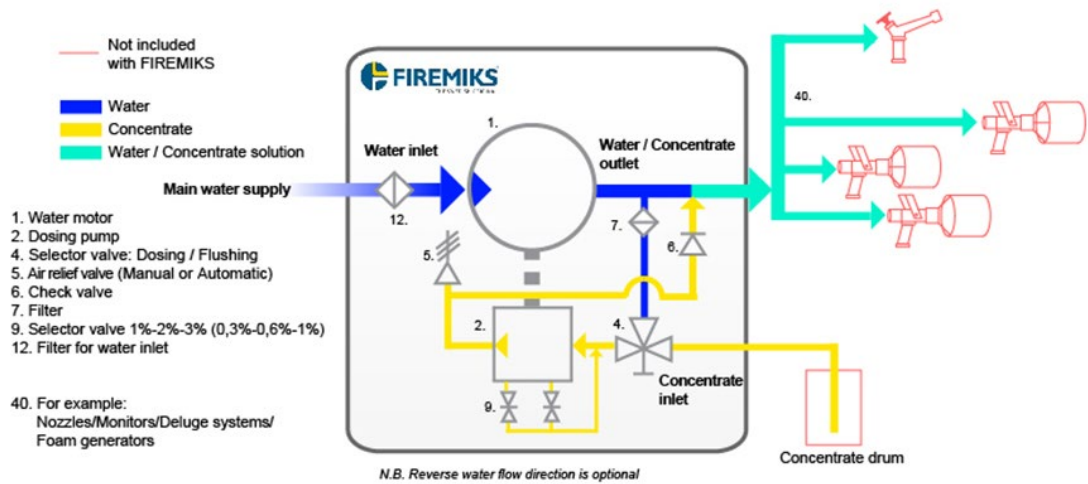

4.10 Selectable admixture 0,5%-1%-3%

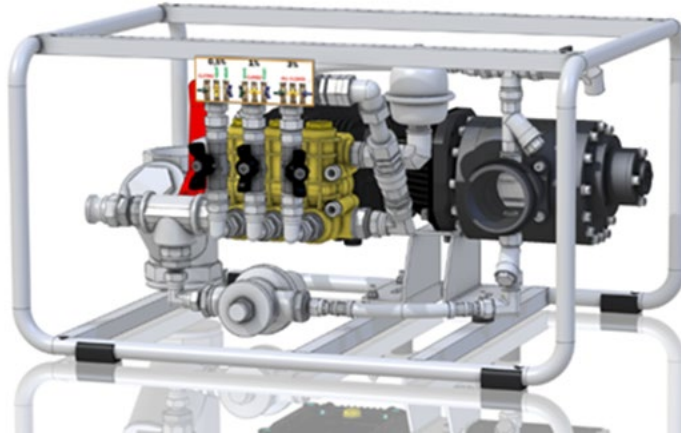

4.10.1 Units can also optionally be specified with a selectable admixture by shortcutting one or two of in total three pistons/plungers. If the unit is equipped with this functionality this will show in its designation, e.g. FIREMIKS 1000-0,5-1-3-PP unit. These models has a piston pump with different piston displacements enabling this dosing selection.

For the shortcuts to work properly the unit must be running in a pressurized installation. Testing with the FIREMIKS water outlet open to the atmosphere will not result in a significant reduced admixture.



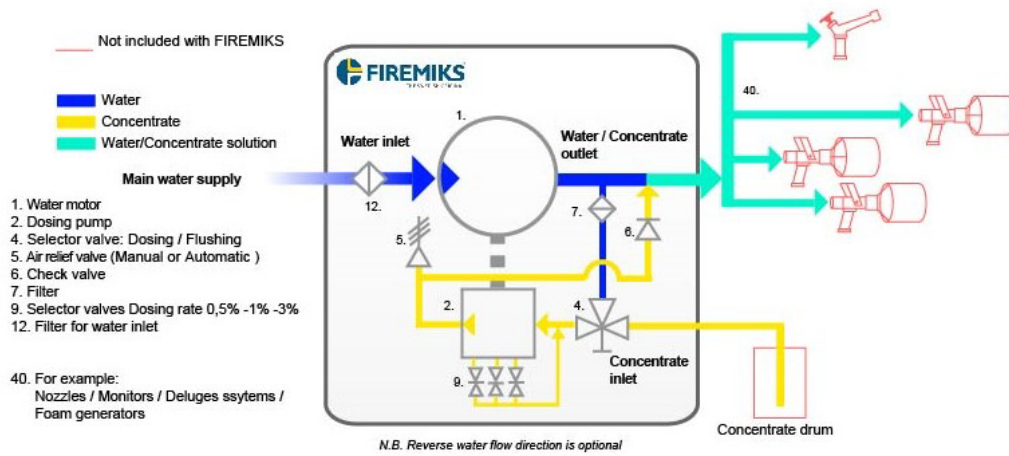

Flow chart 0,5%-1%-3%

4.11 Optional Dosing / Return Valve (DRV)



4.11.1 As an option may units be equipped with an optional Dosing return valve (DRV). **This valve is not to be used during regular operation and its handle should remain positioned for dosing into the main water line only. The valve should only be operated by qualified maintenance/testing personnel for maintenance/testing purposes.**



DRV in dosing position
(normal operation)



DRV in return position
(testing only!)

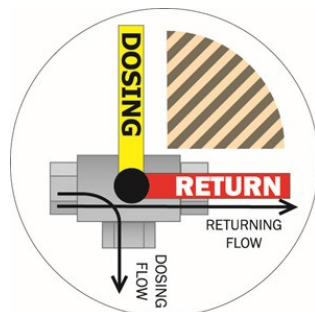



- 4.11.1 A return hose or pipe to the concentrate tank can be connected to the Dosing / Return Valves, making it possible to run the unit with concentrate without creating any mixture and without consuming any concentrate, for testing purposes. **Any valves in this return line or piping mistakenly closed valve can lead to dangerous pressure build-up.** Therefore models equipped with a DRV will always be supplied with a Pressure Relief valve (PRV) **See also 4.12 Pressure relief valve (PRV).**



- 4.11.2 **Note! Beware that with the Dosing / Return Valve in the return position, any flushing done (Selector valve Dosing / Flushing in flushing position (No. 4 on Flow Chart)) will result in water being added into the concentrate tank/drum and possibly make it overflow.**
- 4.11.3 For regular operation, it can be advisable to lock the handle of the valve in the dosing position in order to avoid unauthorized operation of the Dosing / Return Valve. For this reason, this option is not recommended for normal mobile use unless it is really necessary.
- 4.11.4 A dedicated testing system with flow meters, pressure gauges and backpressure valve is available separately.

4.12 Pressure relief valve (PRV)

- 4.12.1 Units equipped with a DRV are always equipped with a Pressure relief valve = PRV, set at factory at a standard 20 bar (unless specified differently, see appendix 2. Dimensional Drawing). **The Pressure relief valve is a safety device only that will trigger in a case of incorrect use of the DRV.** This will cause environmental discharge if the Pressure relief valve discharge port is not connected to a suitable receptacle permanently.



PRV as used on most PP models

4.12.2 If environmental discharge of the concentrate is unwished for by law, environmental concern, convenience or any other reason, the discharge port of the Pressure relief valve must be connected permanently to a suitable receptacle. It can also be routed back to the concentrate tank, in such case it is not allowed to have any fitting or valves in this line that could block the discharge!

4.13 Avoid dry running:



4.13.1 **Note! Do not let the FIREMIKS run dry without concentrate or flushing water. Note! Although the concentrate pumps can withstand some dry running without damage for a limited time, dry running must however never be purposely chosen or relied upon as this will damage the concentrate pump if repeated.** As soon as the concentrate line is empty switch quickly and fully the Selector valve Dosing / Flushing (No 4 on Flow chart) into Flushing position.

Do not hesitate to contact your distributor or Firemiks AB if you have any questions regarding use or set-up of your FIREMIKS!

5 Check before start.

5.1 Check this:

- 5.1.1 Check once again that set-up is made according to instructions above in section **4 Set-up before use**
- 5.1.2 Check that flow and pressure of pump and discharge devices is according to given min-max pressure and flow on the specific product label on the top of water motor on your unit.
- 5.1.3 The main water flow must be in the direction shown by arrows on the upper side of the water motor.



450-3-PP-M-ALU

Flow Rate	100-450 lpm
Admixture	3%
Max Operating Pressure	16 bar
Operating Temperature	1-55 °C
Weight	19 kg
Water Connections	G 50 - 2"
Concentrate Inlet	G 15 - 1/2"



Example of Product label

- 5.1.4 Check that the drain valve on the water motor is closed (no drain valve on 180 and 450 lpm sizes)



Closed Drain valve

- 5.1.5 Make sure that the Drive gear protection is in place and the Protection cap on the back gable side are in place. (Note! On some of the smaller models the dosing pump are connected directly to the Water motor, i.e they have no Drive gear).



DO NOT REMOVE
PROTECTION
WHILE MACHINERY
IS IN MOTION.

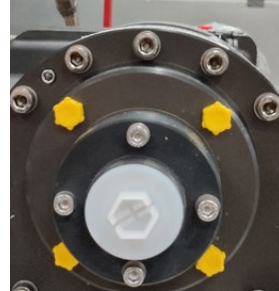

Label on Drive gear protection

Protection cap

- 5.1.6 Check the oil level in the concentrate pump. Use the dip stick or the oil level window if available on your unit. Refill if necessary, according to section 7.4.1



- 5.1.7 Follow the instructions in the next chapter 6

6 Operation

6.1 Optimized start-up and shut down procedures.

6.1.1 Definition of terms

Gravity feed	A steady and sufficient supply of concentrate by gravity to the inlet of the FIREMIKS.
Flushing	Selector valve in Flushing position*
Dosing	Selector valve in Dosing position*

6.1.2 Warnings:



Warning: with the optional Dosing / Return valve connected to the concentrate tank, be careful not to open for Flusing when the Dosing / Return is in Return position, this will fill you concentrate tank with water! See also 4.11.2



Warning: * When switching between Dosing / Flushing, always make a quick change between the end positions. See also 4.8.1



Warning: Do not let the pump run dry. If the concentrate is finished, switch over to flushing! See also 4.13.1

6.1.3 Start of unit

- With all hoses connected and with an available supply of foam concentrate, gently start the main water flow to prevent overflow with the Selector valve Dosing / Flushing (*No. 4 on Flow Chart*) in Dosing position.
- If the supplied Suction pipe is used to pick up the concentrate. Make sure no contamination enters the Suction pipe.
- If suction is made with dedicated concentrate feed line to a foam container on a Fire truck or Foam trailer, ensure all valves from tank are open. See also chapter **4.5.2 Design of the concentrate feed line**.
- If unit is equipped with *Manual* Air relief valve. Shortly open the Manual Air relief valve to let excessive air out and close immediately when foam concentrate comes out.
- If unit is equipped with Automatic Air relief valve, the air release is automatic, no handling needed.
- If for some reason there is no suction of concentrate, you may quickly choose Flushing (*With valve No. 4 on Flow Chart*) to wet the pump and then quickly resume Dosing to help overcome any suction problems, this fills the piston pump with water to support priming. This may happen if the separate Suction pipe is used with an open container and air has entered the piston pump together with some concentrate.
- There should preferably be gravity feed to the unit or at least should concentrate be at the same level as foam pump inlet.
- If unit is equipped with selectable dosing, start always with the highest dosing rate available, to ensure fast priming, then keep it or select the desired lower dosing rate.
- It is possible to change dosing rate without stopping the water flow.

6.1.4 Pressure drop over the unit.

Consult Data sheets for pressure drop figures for each model at different flows, higher flow increases the pressure drop.

6.1.5 Concentrate finished.



When all concentrate liquid is finished, always immediately switch to Flushing with the Selector valve Dosing / Flushing on the concentrate pump inlet (*No. 4 on Flow Chart*). This is to avoid dry running of the concentrate pump.

6.1.6 Shut down.

After using foam concentrate and before stopping the main water flow, put the Selector valve Dosing / Flushing (*No. 4 on Flow Chart*) in Flushing position to flush out the remaining foam concentrate from the pump.

6.2 Admixture details:

- 6.2.1 The nominal admixture is stated in Appendix 1, Data Sheet. Depending on flow and pressure the admixture can vary 1-1,3 x nominal admixture. If the flow goes under the stated minimum flow the admixture will be less. **Note: Minimum water flow rate varies depending on system pressure, viscosity properties of the concentrate and dosing rate.**
- 6.2.2 Units can optionally be specified with a selectable admixture by shortcutting one or two or three of the three pistons/plungers. See chapter **4.9 Selectable admixture 1%-2%-3%, 0,3%-0,6%-1%** and chapter **4.10 Selectable admixture 0,5%-1%-3%**.
- 6.2.3 The unit is equipped with a product label showing min and maxflow, max pressure and nominal admixture. It is placed on the upper side of the water motor.



450-3-PP-M-ALU

Flow Rate	100-450 lpm
Admixture	3%
Max Operating Pressure	16 bar
Operating Temperature	1-55 °C
Weight	19 kg
Water Connections	G 50 - 2"
Concentrate Inlet	G 15 - 1/2"

WATERFLOW

Example

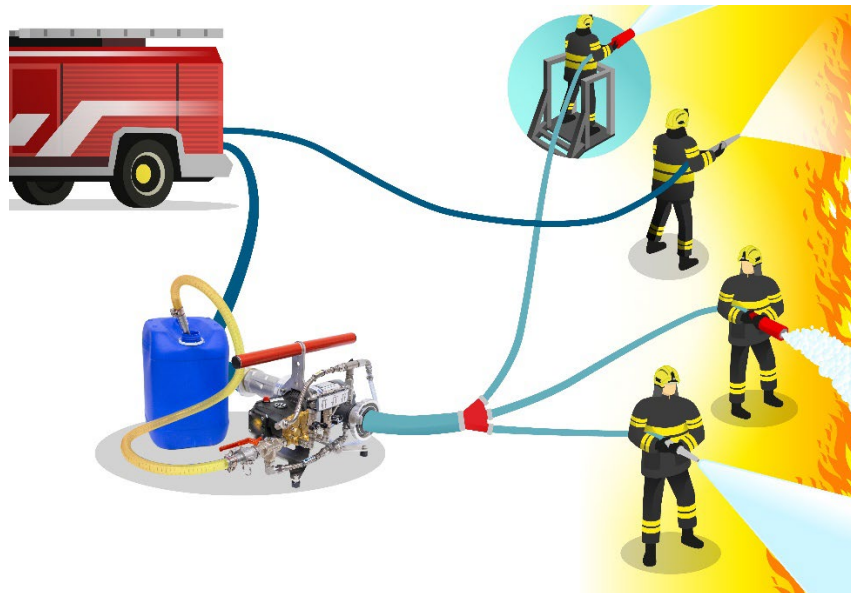
- 6.2.4 FIREMIKS enables central mixing of foam concentrate to several nozzles placed at different lengths and heights from FIREMIKS, handled independently from each other. These can be opened and closed independently of each other without affecting the admixture, as long as the min. and max. limits in pressure and flow of the FIREMIKS are kept.



-
- 6.2.1 **Pulsating use on-off.** During firefighting: when switching the fire nozzle on-off repeatedly, the FIREMIKS will follow the flow and instantly stop and start dosing without any latency as can happen with e.g. electronically controlled systems.
- 6.2.2 An admixture test can be made in several different ways, for example with a refractometer or by measuring the sucked additive at a defined water flow. Note! For units with a selectable dosing rate, the lower dosing rates must be tested in a pressurized system.
- 6.3 **Stop dosing during operation.**
- 6.3.1 When the Selector valve Dosing / Flushing on the concentrate pump inlet (*No. 4 on Flow Chart*) is closed for Dosing it automatically opens for Flushing with water of the concentrate pump. It means you may stop producing admixture and only use plain water for fire-fighting for shorter periods of time. If the unit is intended to operate for an extended period of time (more than 10 minutes) with extinguishing water only, it is better to use a separate hose or a by-pass around the FIREMIKS system to avoid unnecessary wear of the volumetric water motor. **Note! The selector valve handle must only be positioned in its two end positions.**
- 6.3.2 **Note! Although the concentrate pumps can withstand some dry running without damage for a limited time, dry running must however never be purposely chosen or relied upon as this will damage the concentrate pump if repeated. When the concentrate is finished but water flow cannot be stopped, switch the FIREMIKS to flushing position of the Selector valve Dosing / Flushing on the concentrate pump inlet (*No. 4 on Flow Chart*) ASAP**
- 6.4 After operation:
- 6.4.1 After use of the unit in a fire, or in a test with large water flows; check the function according to paragraph 7.3
- 6.4.2 Preventive maintenance measure: when the unit has served in a major fire and the operator wants to ensure optimum future functioning, it may be appropriate to change the Vanes in the water motor. Contact FIREMIKS AB for spare parts and instructions.

7 Maintenance



7.1 **NOTE! Disconnect the unit from any water supply during maintenance so that it cannot start unexpectedly and ensure there is no pressure on the unit.**

7.2 **Once a month:**

7.2.1 Check there are no leakages on the unit or in the connections or couplings.

7.2.2 Be sure to use the unit or at least rotate the unit manually a few full turns once a month if it is not in use. Rotating manually can be done by removing the protection cap on the back gable of the water motor and by using the supplied maintenance wrench to turn the water motor rotor. Note! Do not forget to put back the protection cap. **If initially there is much resistance to rotation which releases once there is movement, increase the rotating interval to once every second week.**



Rotate by hand after making sure the water flow cannot start

- 7.2.3 Check the filter on the flushing line for cleanliness. If the filter is clogged, make sure that it is emptied and returned to its previous placement. System must be depressurized before opening filter cap.

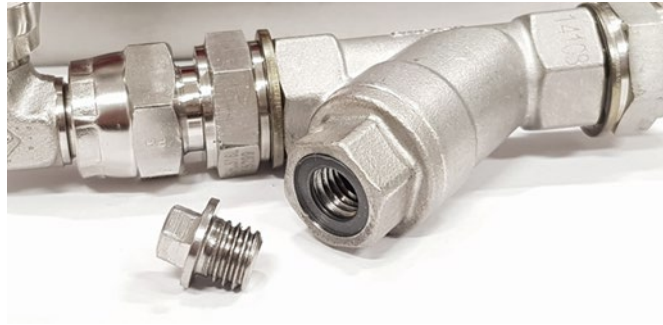

7.3 Once a year at least

- 7.3.1 Complete function test, letting the unit function by mixing additive. This is to check the function of the system. It should be controlled that (i) rotation is smooth, (ii) suction is immediate, and (iii) dosing is within the tolerance. If the unit is not working satisfactorily, read section **8. Troubleshooting**.

- 7.3.1.1 Optional Dosing / Return valve (DRV): This valve may be used to check the function and dosing of the unit. See 4.11 for more information.

- 7.3.1 On units with a drive gear, remove the drive gear protection and check the condition of the drive gear. No cracks, no play on axle and good condition of the plastic insert. Reinstall the drive gear protection. In other cases, replace the drive gear.

- 7.3.2 Change oil in the pump, see next point.

7.4 Pump oil change:

The oil should be changed after the **first year** or **first 50 hours** of operation, whichever comes first. Thereafter, the oil must be changed every year or after 100 hours of operation, whichever comes first.

Oil specification: use a quality automotive oil as follows:

- Engine oil SAE 10W40 or Gearbox oil SAE 80 W-90

Check the dimensional drawing, it may contain more specifications specific for your model. Contact FIREMIKS AB if any questions remain.

7.4.1 Oil change instructions:

- Preferably change the oil after the unit has operated so that the oil will be thinner.
- Find the oil drain plug and put a container under it (3)
- Remove the oil dipstick (1) and then the drain plug (3).
- Wait until all the oil has drained out, then screw the drain plug (3) back in and tighten.
- Fill with new oil until the middle of the oil level indicator (2) is reached, screw back the oil dipstick by hand.

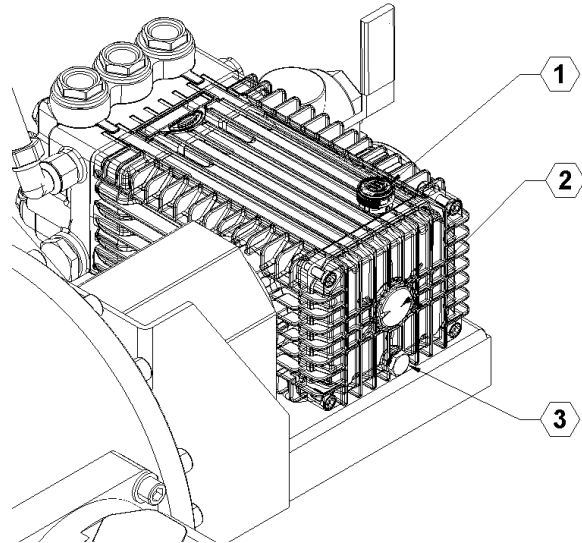

- Note: The extracted old oil must be collected in a suitable container and disposed of in an environmentally responsible way, using the appointed method as required by law at the minimum.

7.5 Replacement of vanes

7.5.1 5-year standard replacement interval

Vanes wear to a varying degree depending on run time, run speed, load, water quality and pollutants, temperature, amount of wear already present, ageing, exposure to excessive heat and overspeed at start-up. To ensure the vanes remain fresh and in as new condition in an event of a fire, the general recommendation is to change vanes at the latest every 5 years on units that are not used a lot. Vanes are part of the 2-5 years recommended spare parts and come with an instruction on how to change the vanes.

Units that are used frequently or run exceptionally long must have a separate maintenance schedule for vane replacement. Examples are intensive monthly test schedules, frequent waste disposal fires, slow burning mine fires, etc. Please contact Firemiks AB for the most suitable replacement schedule for your specific case.

7.5.2 Criteria for changing vanes with frequent use

Vanes must be replaced in the following cases:

- a) Testing shows a measurable drop in dosing performance that cannot be explained by other changes
- b) The vanes have been exposed to more than 70°C
- c) Noise levels increase noticeably with subjectively less smooth running. A baseline measurement can be made with a decibel

meter in identical conditions (same flow and pressure, same measurement point, same environment and installation) preferably close to the water motor, and if noise has increased measurably when the unit is no longer new, more than 2 dB(A), the vanes need to be replaced.

- d) If there is access to the inlet or outlet of the water motor with the piping disconnected, the play on the vanes back and forth should be less than 1mm. If play is higher, vanes must be replaced.

If any of the above criteria have been met and the vanes have been replaced, the next time the vanes should be replaced in half the same use interval or less, to ensure the vanes are fresh in case of an incident.

8 Troubleshooting



- 8.1 **NOTE! It is extremely important that when troubleshooting the unit, when it is not already running, you must assure yourself that the main water flow cannot be started by mistake.**



- 8.2 **NOTE! There is a risk for powerful jet streams of water from leakages when the system is under pressure. Be sure to make the unit (and if necessary the system) without pressure when doing troubleshooting or to wear suitable eye protection.**

8.2.1 If necessary, disconnect the unit from the water supply.

- 8.3 **If the water motor and the dosing pump is rotating but there is no suction of fire-fighting additive, or the admixture is too low:**

- a) If there is no admixture at all, stop the water flow immediately as there is a risk that the dosing pump is running dry that may damage it.
- b) Check if there are any valves in the suction line that are closed or partly closed.
- c) Check that the stated minimum water flow is achieved. Increase if necessary.
- d) **Flush also the dosing pump a couple of seconds by selecting Flushing position on the selector valve (No. 4 on Flow Chart) to flush out any air in the concentrate pump.**
- e) Check that the maximum pressure is not exceeded. Lower the pressure if necessary.
- f) Check the oil level on the oil level indicator on the pump. If the level is too low, fill again to required level and retest.

- g) If the admixture performance has decreased over time to a too low level and none of the previous points could account for this, it is possible that the vanes in the water motor have become too worn. This is accelerated if the water is not free from contaminations (dirt, sand, etc.). If so, contact us to order a set of spare part and for instructions on how to replace the vanes. See also 7.5 **Replacement of Vanes.**

8.4 **Leakage in the unit piping or couplings:**

- a) Check that all pipe couplings are properly tightened. It is important to use two wrenches when doing this. One to tighten and one to hold against.

8.5 **Leakage between gable and middle part on the water motor:**

- a) Check if any screws have become loose. If so, retightening them with the correct tightening torque using a calibrated torque wrench in a slow and deliberate manner. The correct tightening torques are as listed in 10.1. If you ever find an original screw loose, please let us know. **Note! Do not use higher torque as you may cause damage or stretch the screw, so making the assembly less strong.**

- b) If this is not sufficient the O-rings between gable and middle part must be replaced. **See 9.1 Water motor spare parts overview.**



8.6 **Leakage between connection pipe and middle part on the water motor:**

- a) See 8.4 a)

- b) If this is not sufficient the O-rings between connection pipe and middle part must be replaced. **See 9.1 Water motor spare parts overview.**

8.7 **Water motor rotor and dosing pump is difficult to rotate with crank on the rotor shaft end:**

- a) Should a unit be difficult to rotate, check the unit by putting the Selector valve Dosing / Flushing (*No. 4 on Flow Chart*) in Fushing position and let the specified minimum flow of water go through the unit for a couple of minutes, to flush out foreign particles, etc. **Note! The selector valve handle must only be positioned in its two end positions.** If there are no unusual noises and the unit has an easy rotation after flushing, this is normally sufficient.

- b) If the guidelines in section **7.1 Maintenance** have not been followed, the dosing pump may seize and refuse to rotate. Contact us on how to proceed.

- c) If the problems remain after acting accordingly to the above, or if

there are heavy unusual noises, immediately stop using the unit and contact us for detailed guidance in each case.

8.8 **The maximum water flow is not achieved:**

- a) Make sure the FIREMIKS is rotating properly according to section 7.2.
- b) Check if there are restrictions in the piping system before or after the unit. Remove them if necessary.
- c) Check if any filter or other valves in the main line is filled with pollution. Clean if necessary.
- d) Check that the main water pump is working correctly and that there are no air leakages affecting this pump.

8.9 **Excessive vibration/noise:**

- a) Excessive, previously unheard, vane noise (loud ticking) can be heard from the water motor during operation. If this occurs on a used unit, this can be an indication that the vanes are worn and need replacement.
- b) For units equipped with a drive coupling between the water motor and concentrate pump, these have been aligned at the factory. However, if they for any reason, e.g. during transport, became out of alignment, this will cause excessive vibration and noise. This should be adjusted as soon as possible as it can cause excessive wear and material failure. See illustration below for allowable tolerances.

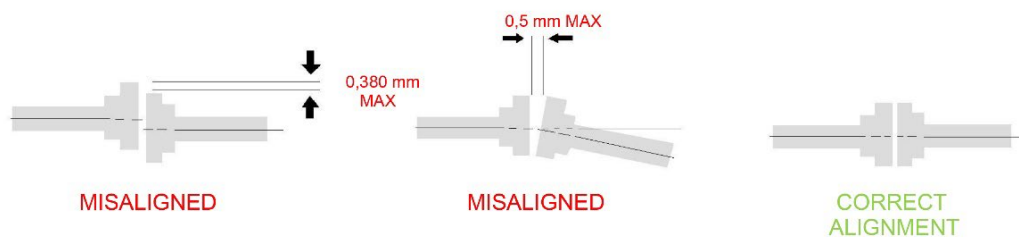

For any issue, do not hesitate to contact us if questions arise!

9 Spare parts

9.1 FOR ORDERING SPARE PARTS: Please state: - Serial number of the complete unit - Ref.nr. and part name(s), and quantity requested.

9.2 Water motor spare parts

Rev/No	Revision note	Date	Signature	Checked

Ref. nr.	#	Part name	Material	Material Alt. version
1.10	1	Set of Vanes (5 or 4 pcs) (Fasteners incl.)	PEIG	
1.20	1	Set of Mechanical seals (2 pcs)	Car/SiC/ P/SS304	
1.30	1	Set of Ball Bearings (2 pcs)	ASI 440C, NBR	
1.40	1	Set of O-rings (8 or 6 pcs)	NBR 70	
1.45	1	Set of gable inserts (2 pcs)	POMI	

Ref. nr.	#	Part name	Material	Material Alt. version
1.50	1	Complete Rotor (Fasteners incl.)	Al-7075-T6	JM7 (C 98500)
1.60	1	Middle Part (O-rings, fasteners and pin incl.)	Al-6062-T6	JM7 (C 98500)
1.70	2	Gable (O-rings, fasteners and pin incl.)	Al-6062-T6	JM7 (C 98500)
1.80	2	Connection Pipes	Al-6062-T6	JM7 (C 98500)
1.90	1	Set of Ball Bearing Supports (2 pcs, incl. fasteners)	Al-6062-T6	JM7 (C 98500)

Finish: Hard anodised PTFE modified

Note:
 All fasteners: Stainless steel AISI 316
 O-rings: NBR

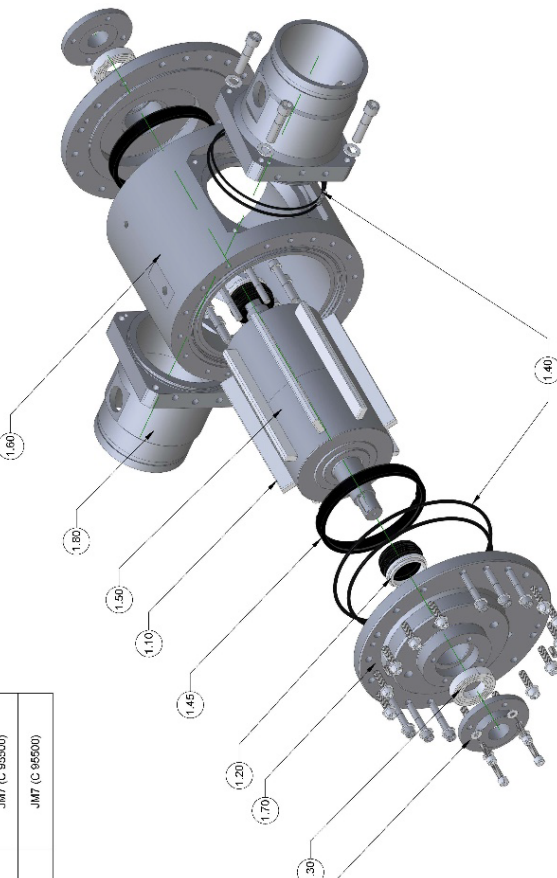

FOR ORDERING SPARE PARTS:
 Please state:
 - Serial number of the complete unit
 - Ref.nr. and part name(s), and quantity requested

Drawn by WALLE	Checked by	Approved by - date	Date 2023-10-01	Scale - Paper size A3
Firemiks AB P.O. Box 8155 SE-44101 M, Sweden info@firemiks.com		SPARE PART DRAWING MATERIALS FIREMIKS WATER MOTOR ALU or BRZ Copyright of Firemiks AB All rights reserved - Reproduced use only		Edition 1 of 1 Sheet 1 of 1

9.3 Piston Pump spare parts

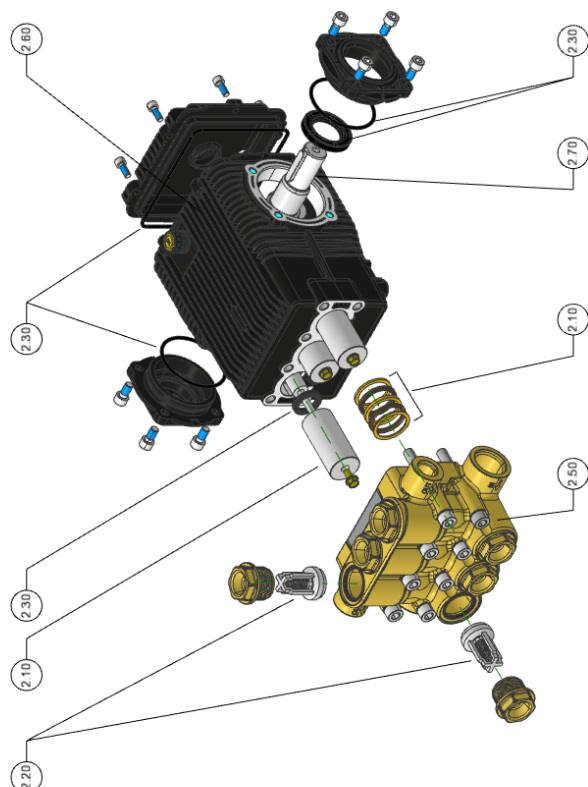
1	2	3	4	5	6	7	8	9	10																																										
				RevNo	Revision note	Date	Signature	Checked																																											
<p>Recommended spare parts:</p> <table border="1" style="width:100%; border-collapse: collapse;"> <thead> <tr> <th>Ref.nr.</th> <th>#</th> <th>Part name</th> <th>Materials</th> </tr> </thead> <tbody> <tr> <td>2.10</td> <td>1</td> <td>Water seals and plunger kit</td> <td>NBR, Ceramic</td> </tr> <tr> <td>2.20</td> <td>1</td> <td>In / Out valve kit</td> <td>POM/PA66 cage Stainless steel valve</td> </tr> </tbody> </table>		Ref.nr.	#	Part name	Materials	2.10	1	Water seals and plunger kit	NBR, Ceramic	2.20	1	In / Out valve kit	POM/PA66 cage Stainless steel valve	<p>Other spare parts</p> <table border="1" style="width:100%; border-collapse: collapse;"> <thead> <tr> <th>Ref.nr.</th> <th>#</th> <th>Part Name</th> <th>Materials</th> </tr> </thead> <tbody> <tr> <td>2.30</td> <td>1</td> <td>Oil seals kit</td> <td>NBR</td> </tr> </tbody> </table>		Ref.nr.	#	Part Name	Materials	2.30	1	Oil seals kit	NBR	<p>Materials remaining components</p> <table border="1" style="width:100%; border-collapse: collapse;"> <thead> <tr> <th>Ref.nr.</th> <th>#</th> <th>Part Name</th> <th>Materials</th> </tr> </thead> <tbody> <tr> <td>2.50</td> <td>1</td> <td>Pump head</td> <td>Brass CW617N or similar (or AISI 316L for optional SS head)</td> </tr> <tr> <td>2.60</td> <td>1</td> <td>Body/carter</td> <td>Cast-iron/brass Aluminum (EN AB-46100 or similar)</td> </tr> <tr> <td>2.70</td> <td>1</td> <td>Crank shaft</td> <td>Hardened steel * T-edy corrosion protection</td> </tr> <tr> <td></td> <td></td> <td>Remaining O-rings</td> <td>NBR</td> </tr> </tbody> </table>		Ref.nr.	#	Part Name	Materials	2.50	1	Pump head	Brass CW617N or similar (or AISI 316L for optional SS head)	2.60	1	Body/carter	Cast-iron/brass Aluminum (EN AB-46100 or similar)	2.70	1	Crank shaft	Hardened steel * T-edy corrosion protection			Remaining O-rings	NBR	<p>FOR ORDERING SPARE PARTS:</p> <p>Please state:</p> <ul style="list-style-type: none"> - Serialnumber of the complete unit - Ref.nr. and part name(s), and number of complete kits requested 				<p>IMPORTANT:</p> <p>Supplied spare part kits contains all spare parts necessary for each type of pump kit.</p> <p>The kits are correct ONLY for the pump model tied to the serial number provided.</p>	
Ref.nr.	#	Part name	Materials																																																
2.10	1	Water seals and plunger kit	NBR, Ceramic																																																
2.20	1	In / Out valve kit	POM/PA66 cage Stainless steel valve																																																
Ref.nr.	#	Part Name	Materials																																																
2.30	1	Oil seals kit	NBR																																																
Ref.nr.	#	Part Name	Materials																																																
2.50	1	Pump head	Brass CW617N or similar (or AISI 316L for optional SS head)																																																
2.60	1	Body/carter	Cast-iron/brass Aluminum (EN AB-46100 or similar)																																																
2.70	1	Crank shaft	Hardened steel * T-edy corrosion protection																																																
		Remaining O-rings	NBR																																																
				Drawn by	Checked by	Approved by - date	Date	Scale - Paper size A3																																											
				Firemiks AB		VAT no: SE556799509501	SPARE PART DRAWING 2																																												
				www.firemiks.com		Copyright of Firemiks AB		PISTON PUMP with materials																																											
				info@firemiks.com		+46-8-551 196 10		Edition	Sheet																																										
								1 of 1	1 of 1																																										

ALSO VALID FOR DUAL HEAD PUMPS
Every kit contains the number of parts necessary to service ALL pistons (3 or 6).

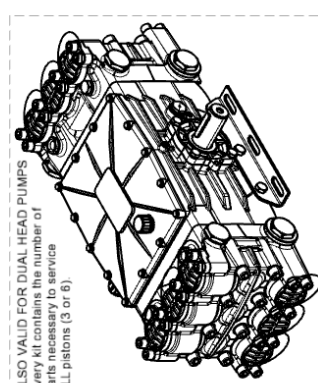

9.4 Complete unit spare parts

1	2	3	4	5	6															
<p>Recommended spare parts:</p> <table border="1" style="width:100%; border-collapse: collapse;"> <thead> <tr> <th>Ref.nr.</th> <th>#</th> <th>Part Name</th> </tr> </thead> <tbody> <tr> <td>3.11</td> <td>1</td> <td>Manual air relief valve</td> </tr> <tr> <td>3.20</td> <td>1</td> <td>Check valve</td> </tr> <tr> <td>3.30</td> <td>1</td> <td>Complete drive gear + Wedges</td> </tr> <tr> <td>3.40</td> <td>1</td> <td>Filter or filter/flushing valve</td> </tr> </tbody> </table>		Ref.nr.	#	Part Name	3.11	1	Manual air relief valve	3.20	1	Check valve	3.30	1	Complete drive gear + Wedges	3.40	1	Filter or filter/flushing valve	<p>Revision note</p>		<p>Signature</p>	<p>Checked</p>
Ref.nr.	#	Part Name																		
3.11	1	Manual air relief valve																		
3.20	1	Check valve																		
3.30	1	Complete drive gear + Wedges																		
3.40	1	Filter or filter/flushing valve																		
				<p>Date</p>																
				<p>Approved by - date</p>	<p>Scale</p>															
				<p>Checked by</p>	<p>File name</p>															
				<p>Drawn by WALLE</p>	<p>Date 2020-12-30</p>															
				<p>Firemiks AB P.O.Box 8155 SE-104 20 STOCKHOLM, Sweden info@firemiks.com +46-8-551 196 10</p>	<p>SPARE PART DRAWING 3 FIREMIKS PP COMPLETE Copyright of Firemiks AB All rights reserved - Authorised use only</p>															
				<p>3</p>	<p>6</p>															
				<p>2</p>	<p>6</p>															
				<p>1</p>	<p>6</p>															

FOR ORDERING SPARE PARTS:

Please state:
 - Serialnumber of the complete unit
 - Ref.nr. and part name(s), and quantity requested

Notes:
 1) For water motor parts, see separate list
 2) For dosing pump parts, see separate list

Other spare parts

Ref.nr.	#	Part name
3.50	1	Pump bracket (Fasteners incl.)
3.60	1	Drive gear protection (Fasteners incl.)
3.70	1	Ball valve inlet concentrate pump
3.75	1	Supervisory Switch (Fasteners incl.)
3.90	1	Drain valve
3.100	1	Set of complete dosing line (Couplings, hose and check valve)
3.110	1	Set of complete flushing line (Couplings, hose and filter (valve))
3.120	1	Complete dosing pump (incl. fasteners)
3.130	1	Complete water motor
3.140	1	(optional equipment: dosing return valve)
3.150	1	(optional equipment with dosing return valve: Pressure relief valve)

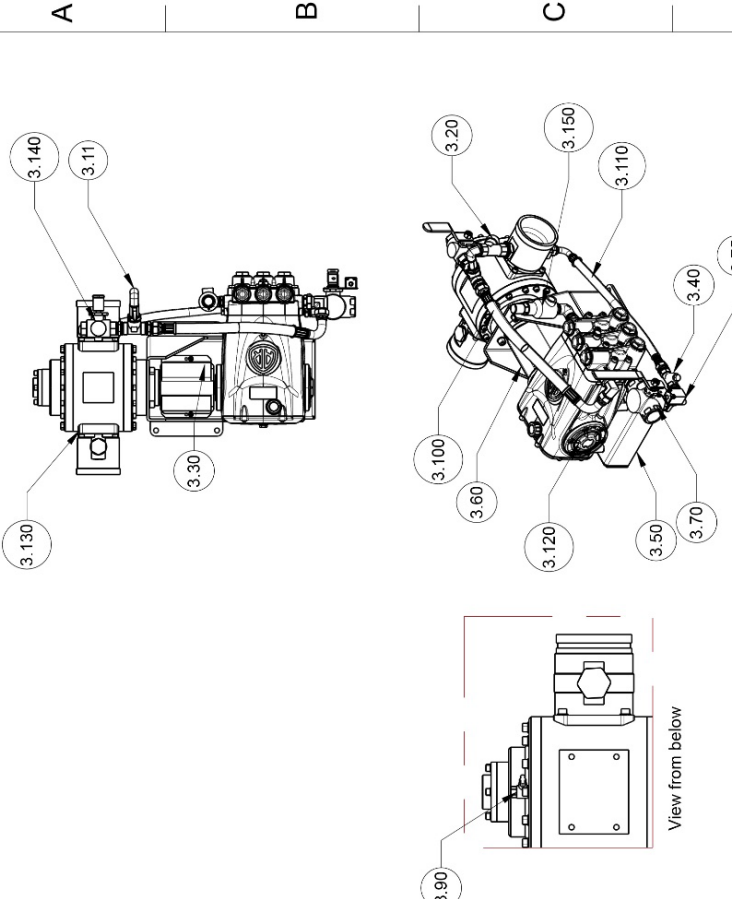

View from below

10 Tables Tightening torque

- 10.1 Table 1: **Tightening torque stainless steel screws for FIREMIKS, except the concentrate liquid pump.**

Screw material: A4-70		Screw material: A4-80	
Dimension	Tightening torque (±5%)	Dimension	Tightening torque (±5%)
M6	7 Nm	M6	9 Nm
M8	17 Nm	M8	22 Nm
M10	33 Nm	M10	43 Nm
M12	57 Nm	M12	75 Nm
M14	89 Nm	M14	119 Nm
M16	136 Nm	M16	181 Nm

- 10.2 Table 2: **Tightening torque for concentrate liquid pump only (to be used for maintenance).**

Dimension	Tightening torque (±5%)
M6	11Nm
M8	21Nm
M10	39Nm

11 Material recycling guide

- The materials included in the FIREMIKS system are aluminum, bronze, stainless steel, brass, rubber (NBR) and plastic (PETF). The seals include very small amounts of ceramic material (below 50 gram)
- Applicable regulations and legislation: The system contains no material which is subject to special rules that affect the recovery.
- Marking of materials: The various components of the system are not individually marked. An exploded view attached shows the different parts and what materials they are composed of.
- Recyclability: The parts of aluminum, bronze, stainless steel and brass can be recycled as scrap metal. These make up an estimated 95% of the total system weight. Rubber and plastic components can be recycled in accordance with normal procedures for rubber and plastics. The small volumes of ceramic materials in the seals and concentrate pump cannot be recycled.
- Ingredients and Units: The water motor consists essentially of aluminum and the motor wings of plastic (PETF). The O-rings are made of rubber (NBR). The concentrate pump is made of bronze. The drive coupling is aluminum. The pump bracket, screws and piping consist of stainless steel. The couplings are made of brass. As stated above there is ceramic material (<50 g) in the seals and concentrate pump.
- Data for decontamination and dismantling of the system: The system contains no chemicals or ionizing radiation. After using the concentrate liquid, normally the system is easily flushed with water. As the concentrate liquid is not part of this unit, Firemiks AB cannot comment on the recyclable nature of the concentrate.



12 Overview and repetition of paragraphs essential for safety

(2) **Read this first!**

The whole section 2 is important to read!

(4) **Set-up before first use**

(4.2.2) DO NOT lift the unit using the piping or hoses, always lift the unit using the frame or carrying handle!

(4.11.1) As an option may units be equipped with an optional Dosing return valve (DRV). **This valve is not to be used during regular operation and its handle should remain positioned for dosing into the main water line only. The valve should only be operated by qualified maintenance/testing personnel for maintenance/testing purposes.**

(4.13.1) **Note! Do not let the FIREMIKS run dry without concentrate or flushing water.**

(5) **Check before start.**

(5.1.5) **Make sure** that the Drive gear protection is in place and the Protection cap on the back gable side are in place. (Note! On some of the smaller models the dosing pump are connected directly to the Water motor, i.e they have no Drive gear).

(0) **Operation**

(6.1.2) Read the warnings on page 28

(6.2.3) The unit is equipped with a product label showing min and maxflow, max pressure and nominal admixture. It is placed on the upper side of the water motor.

(8) **Troubleshooting**

(8.1)8.1 **NOTE!** It is extremely important that when troubleshooting the unit, when it is not already running, you must assure yourself that the main water flow cannot be started by mistake.

(8.2) **NOTE!** There is a risk for powerful jet streams of water from leakages when the system is under pressure. Be sure to make the unit (and if necessary the system) without pressure when doing troubleshooting or to wear suitable eye protection.

FIREMIKS[®] is a registered trademark owned by Firemiks AB. We reserve the right to make changes in the specifications without prior notice.