



WATER DRIVEN VOLUMETRIC PROPORTIONERS FOR FIRE FIGHTING

FIREMIKS is a reliable and easy-to-use

pump proportioner, driven by the water flow only.

www.firemiks.com

ABOUT

Firemiks AB is a Swedish company with a background history from 1979 of developing and producing water driven volumetric proportioners.

Since 2010 we brand our units **FIREMIKS** - a reliable and easy-to-use foam pump proportioner, driven by the water flow only.

“ OUR MISSION

To provide reliable, efficient and high-quality dosing systems for fire fighting in every part of the world.

OUR VISION

Steadily reduce loss in human lives, property and environmental damages by making the world better equipped to stand against fire disasters.

”



OUR DISTRIBUTORS

During the years we have supplied FIREMIKS-units to more than **50 countries world-wide.**



UNIQUE WATER MOTOR

- Unique in-house designed volumetric multivane water motor in many sizes. Multiple overlapping vanes results in spreading of loads and a wide volumetric function, without using moving elastomer sealing or spring-loaded vanes.
- The robust multi-vane motor gives low noise, smooth start and rotation.
- Modular system and machined parts allow for tailor-made solutions to meet specific customer dosing challenges.

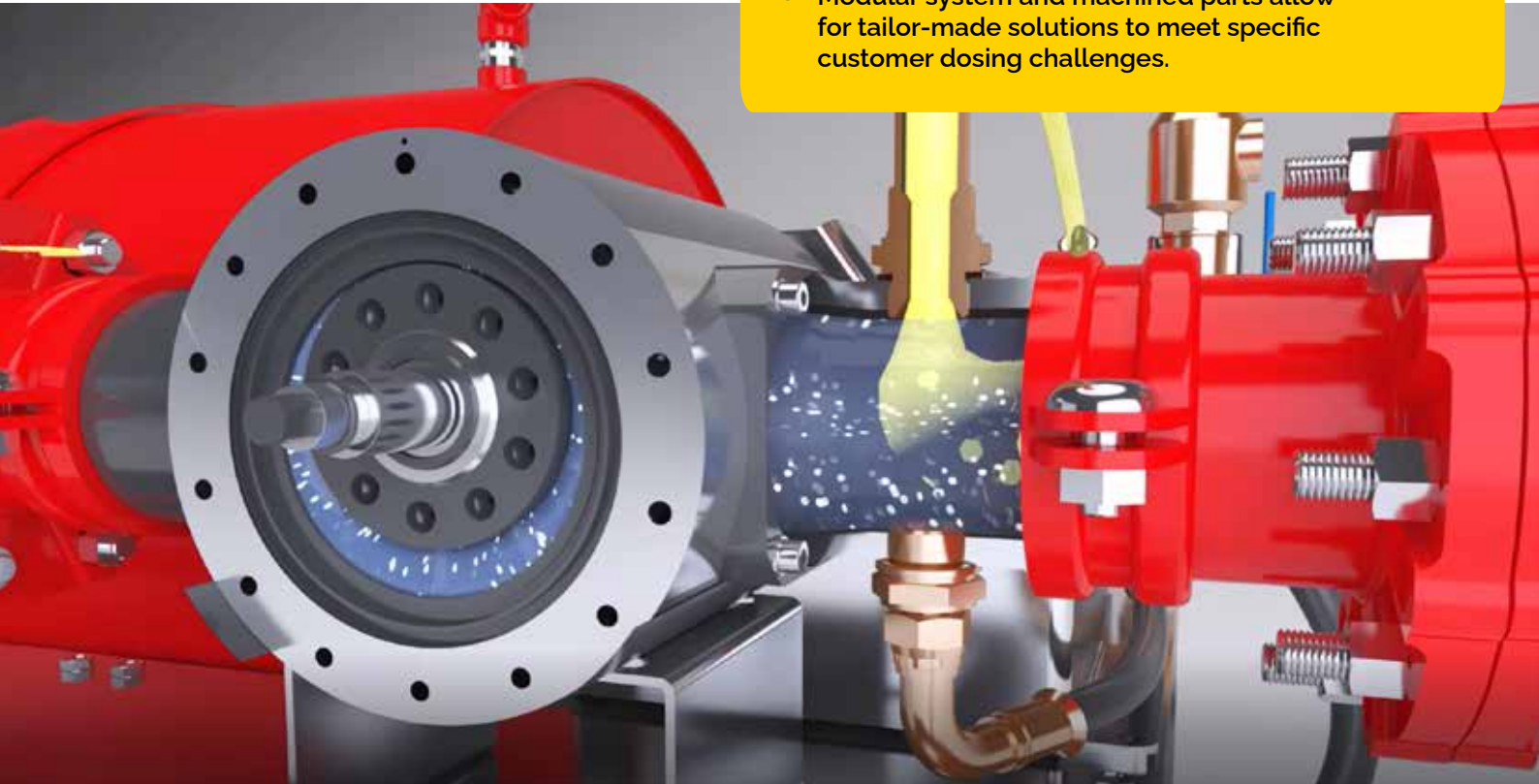

EASY TO INSTALL

COMPACT DOSING SYSTEM, NO NEED OF PRESSURE TANK OR ADDITIONAL ENERGY SUPPLY

- There is no need for an additional proportioner, pressure tank or electrical/diesel motor. Just connect to an atmospheric concentrate tank easy to refill, even during action.

EASY TO USE

RELIABLE MECHANICAL PROPORTIONER, DRIVEN BY THE WATER FLOW ONLY, NO NEED FOR PRESSURE BALANCING

- Proportioning is automatic as the FIREMIKS dosing rate is inherent to the volumetric relation between the water motor and the concentrate pump, meaning it works in a wide flow- and pressure range. Driven by the water flow only, no need for complicated pressure balancing and/or calibration.

EASY TO TEST

ECONOMICAL AND ENVIRONMENTALLY BENEFICIAL TESTING WITH A DOSING RETURN VALVE AND SEPARATE FLOW METERS

- All units can be supplied with a Dosing return valve (DRV). This returns the concentrate back to the tank during a test, an important environmental benefit. This results in substantial cost savings, with no cleaning up or destruction of dispersed foam. The respective water and concentrate flows should be measured with independent flow meters to calculate accurate dosing rate.

SIMPLIFYING PROPORTIONING

Fighting fires with flammable material in high hazard environments is a challenging task. To work with reliable and simple systems is paramount.

The use of **FIREMIKS** simplify the correct dosing of the concentrate for both fixed system and mobile fire fighting.

LET **FIREMIKS** TAKE CARE OF THE CORRECT PROPORTIONING - SO YOU CAN FOCUS ON FIGHTING THE FIRE!



NO NEED FOR PRESSURE BALANCING

Correct proportioning is made automatic. **FIREMIKS** inherently works in a wide flow- and pressure range.

There is no need for pressure balancing or calibration.

VERY EASY START-UP, FIREMIKS DOES NOT USE ADDITIONAL CONTROL LOOPS THAT NEED FINE-TUNING OR THAT CAN OSCILLATE.

EASY TO CREATE A FLEXIBLE SYSTEM

When using a FIREMIKS the firefighters get a flexible system, easy to adapt to different firefighting situations. The unit works within a wide pressure and flow range.

One can use several nozzles at the same time, quickly open and close them (pulsing), and place them at different distances and heights from FIREMIKS, fire pump or hydrant supply without affecting foam quality.

Lower pressure losses compared with Inductor giving longer throw length.

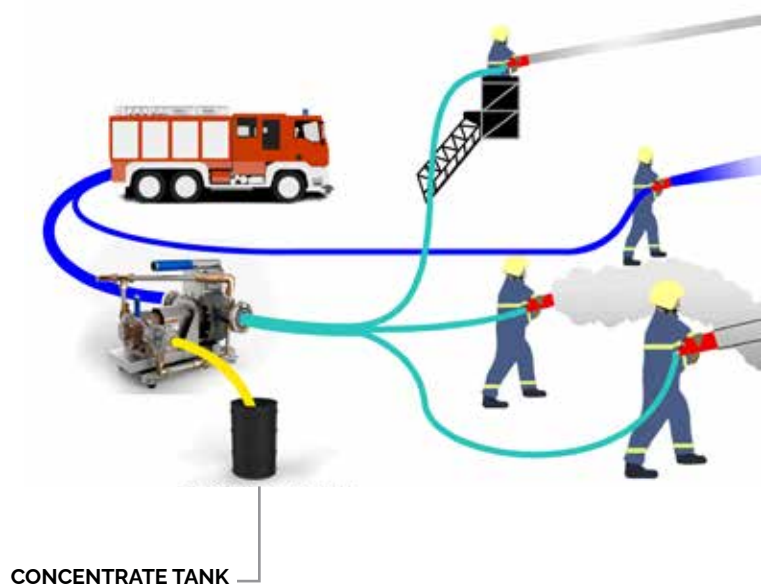

WORKING PRINCIPLE

FLOW DRIVEN

The water flow goes through the **FIREMIKS** positive displacement water motor. This generates an axial rotation, transferred to the dosing pump over the direct drive coupling.

Since the water motor functions both as a drive to the dosing pump and as a volumetric metering device, the system becomes by that flow proportional: dosing remains within approved tolerance regardless of variations in the water flow, within the limits of the data sheet.

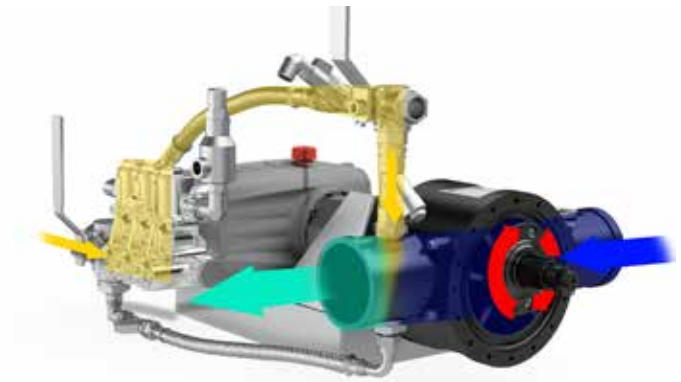

● WATER ● CONCENTRATE ● WATER/CONCENTRATE

PRINCIPLE FLOW CHART

- NOT INCLUDED
- WATER
- CONCENTRATE
- EXTINGUISHING SOLUTION

1. Water motor
2. Dosing pump
3. Drive coupling
4. Selector valve: Dosing/Flushing
5. Manual/automatic air relief valve
6. Check valve
7. Filter
8. Drain valve
9. For example: Sprinkle heads /Nozzles/Monitors

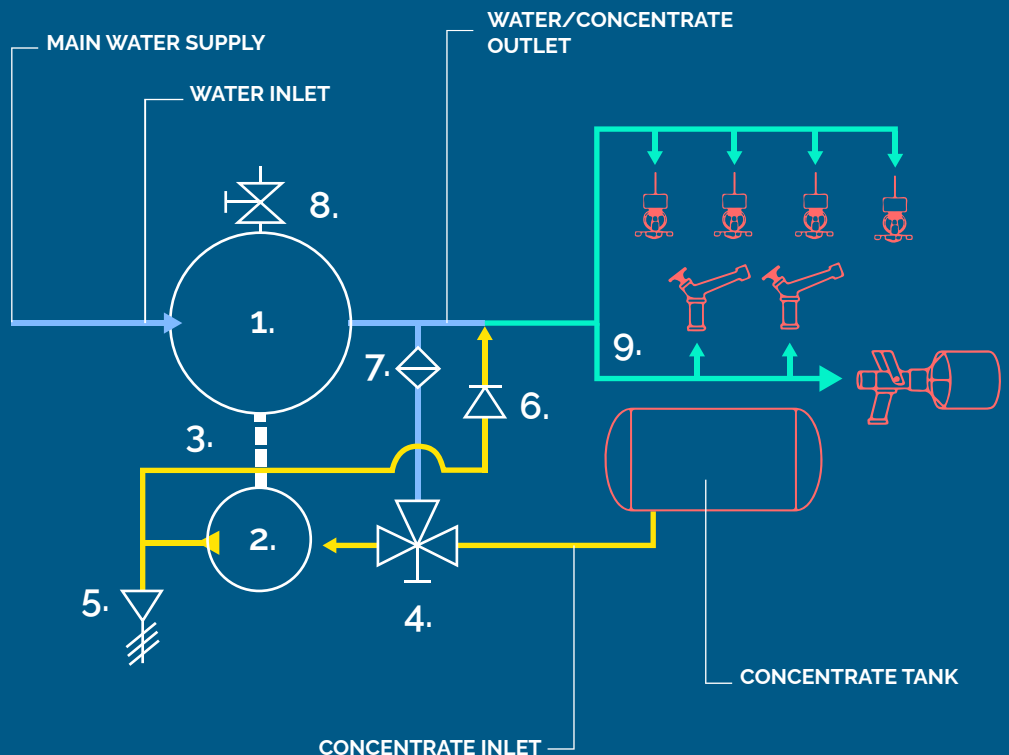

N.B. Reverse water flow direction is optional.

APPLICATIONS

INDUSTRIAL



FIXED INSTALLATIONS

FIRE BRIGADES



MOBILE USE

MARINE / OFFSHORE



BOATS AND SHIPS



FOAM TRAILERS



FIRE TRUCKS



OFFSHORE

EXAMPLES OF AREAS TO BE PROTECTED USING FIREMIKS FOAM PROPORTIONER

Tank farms, Petrochemical industry, Harbor Jetties, Pump rooms, Warehouses, Waste incineration, Tunnel protection, etc.

I. e. anywhere where there is a requirement for foam proportioning system to protect highly flammable material with Class B foam.

FIREMIKS is also well suited for enhancing Sprinkler system with additives/foams.

Furthermore, **FIREMIKS** is suitable for dosing Class A foam, for example with 0,3-0,6-1% to fight bush and forest fires.

Custom dosing rates and flow ranges available.



DOSING RETURN VALVE

With the option Dosing return valve (DRV) it is possible to practice and test dosing rate without consuming the concentrate. This feature gives substantial savings over many years with no cost for cleaning or destruction of the solution after the test. A Pressure relief valve (PRV) is included to avoid the risk for over-pressure if the return line is closed when DRV is open. The respective water and concentrate flows should be measured with independent flow meters to calculate accurate dosing rate.



FM APPROVAL

FIREMIKS has a selected line of FM approved models according to FM approval Class 5130, with water motor in Hard-anodized aluminium, Ni-Al Bronze or Stainless-steel ASTM 316L.



PISTON PUMP TYPE

FOR INDUSTRIAL APPLICATIONS

Our **FIREMIKS** equipped with **Piston pumps (-PP)** are particularly suited for use in systems with low start flows, for example sprinkler systems. Piston pumps are also very suited for low and medium viscosity concentrates. The unit shall be placed in such a manner that the concentrate has a free flow down from the foam tank to the dosing pump. With our Piston pump models we can offer units with three selections of dosing percentages with just one pump, by adding small selector valves on the piston pump. For example, we can offer 1-2-3%, 0,3-0,6-1%. Also 0,5-1-3% on selected models. You may change dosing percentage even while unit is in action.

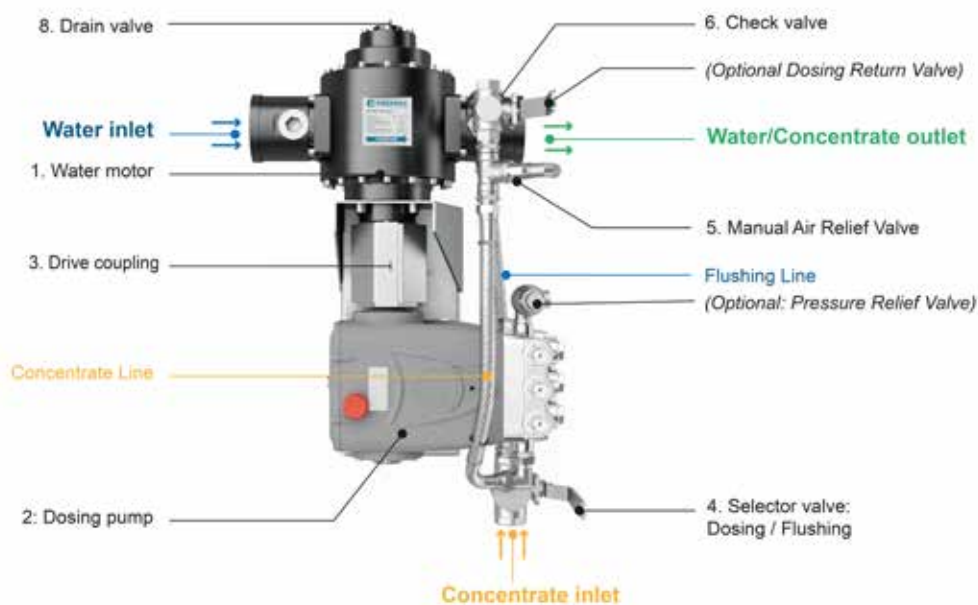

PISTON PUMP WORKING PRINCIPLE

Piston/plunger Pumps (-PP) is a reciprocating pump and perform at their best at low and medium viscosities due to the Piston pump principle; for each revolution the plunger sucks concentrate and then presses it out and the concentrate goes from zero to full speed twice per revolution. Important to know is that Piston pumps have a limit upwards to high viscosity concentrates for correct dosing. If the static viscosity is too high, above around 4,000 – 4,500 cSt (30 rpm, #4) with non-Newtonian concentrates, the concentrate will not flow smoothly and therefor the correct dosing rate might not be achieved.



GEAR PUMP TYPE

FOR INDUSTRIAL APPLICATIONS

A sturdy pump with minimum maintenance. Our FIREMIKS provided with a Gear pump (-GP) is particularly suited for working in the higher end of a systems maximum flow rate, such as deluge installations and full flow monitors. Gear pumps are also very suited for high and very high (up to at least 8000 cP, 30 rpm, #4) viscosity concentrates, incl Fluor-free foams.

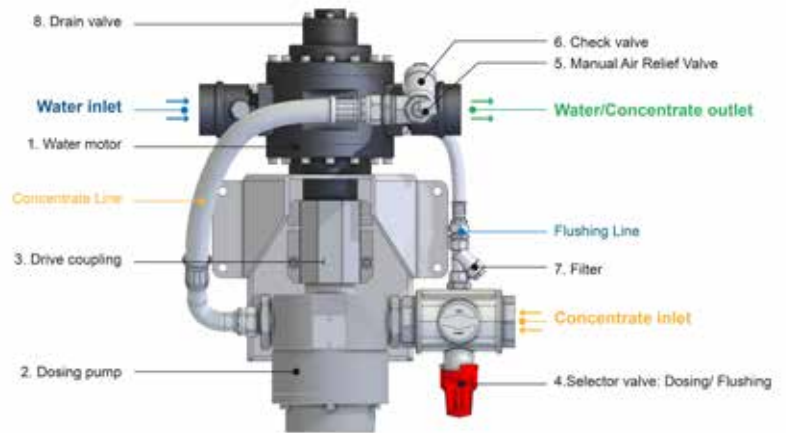

BELT DRIVEN GEAR PUMP

Firemiks AB has released the next generation Gear Pump solutions for larger models. With these models, the Gear Pump is mounted on top of the water motor, making for an even more compact package. Instead of direct drive with a drive gear coupling, the Gear Pump is now driven by an industrial multi V-rib belt. This arrangement makes it possible to optimize both the Water motor and Gear pump more independent from each other with different rotating speeds, continuing the Firemiks tradition of offering the best possible solution for the customers' specific dosing case. Please refer to the datasheet for each model.

GEAR PUMP WORKING PRINCIPLE

A Gear pump uses internal gear to grab the concentrate. The advantages of using Gear pumps are that they are sturdy, flow is not pulsating, and they "grip" high viscosity concentrates very well.



UNITS FOR MOBILE USE

FIREMIKS Mobile units can be supplied with either Gear pump (-GP) or Piston pump (-PP). The main difference between these two types, apart from suitability for different viscosities, is that on Piston pump models we can offer three different dosing rates, 1-2-3%, 0,5-1-3% or 0,3-0,6-1% with just one foam pump.

The Mobile units are complete with suction tube and automatic air relief valve to speed up priming. They are equipped with a bottom bracket and carrying handle, or a surrounding cage frame, making them easy to handle. For larger sizes we equip the units with wheels to make them easy movable.

OVERVIEW OF MAIN PARTS

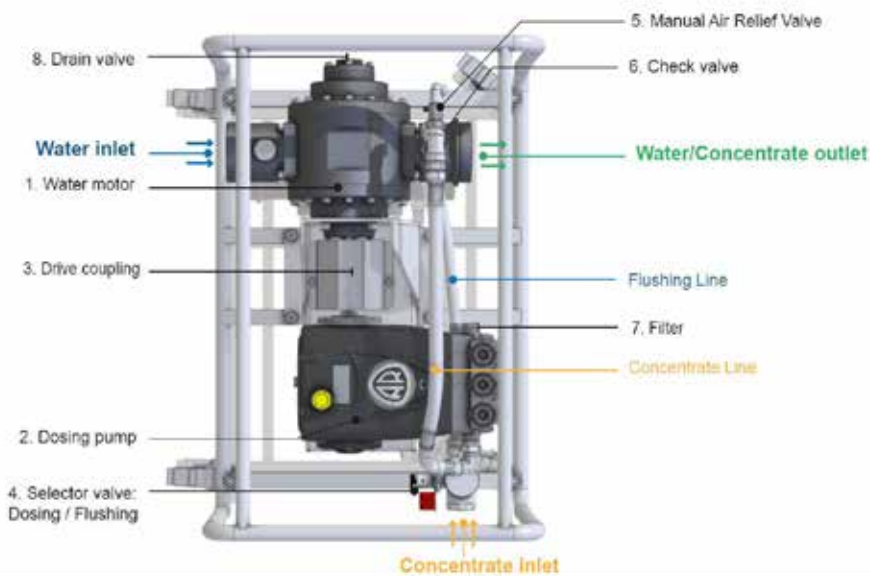

All Mobile models are equipped as standard with SS-water strainer on water motor inlet.



FOREST/BUSH FIRE FIGHTING

FIREMIKS is a handy and effective mobile proportioning system when fighting forest/bush fires with low dosing rates (for example 0,3% or 0,5%) of additives proportioned from long distances. A great advantage when the terrain is hilly, and the distance is long from the main pump to the fire area.

TWO ALTERNATIVE DESIGNS



WITH HANDLE AND BOTTOM BRACKET



WITH STURDY SURROUNDING FRAME

UNITS EQUIPPED WITH PISTON PUMP

Mobile Piston pump models are suitable when one or several of the following parameters are required:

- Use with low up to medium viscosity concentrates
- Easy selection of different dosing rates
- Low start up flow.

Flow sizes from smallest size max flow of 180 lpm up to largest size 2400 lpm, For fixed dosing rates 1%, 2% or 3% or for selectable dosing rates, e.g. 0,3-0,6-1%, 1-2-3%. 0,5-1-3% on selected models.



UNITS EQUIPPED WITH GEAR PUMP

Mobile Gear pump models are suitable when one or several of the following parameters are required:

- Use with high - up to very high - viscosity concentrates.
- Simple sturdy pump with minimum maintenance
- One fixed dosing rate
- Particularly suited to be used at the higher end of a unit's flow rate

Smallest model max flow 800 lpm – largest 2400 lpm with 3% fixed dosing rate. (Fixed 1%, 2% or 6% is available at request).



Originally founded in 1979 as a Swedish family-based business
- Firemiks AB is operated by the third generation, together with strong industrial partners.

Throughout the years, our focus has been to develop, manufacture and distribute our own line of
water driven volumetric proportioners worldwide.



Phone: +46-8-551 196 10
Email: info@firemiks.com

Address: Mätarvägen 9A,
SE-196 37 KUNGSÄNGEN,
Sweden

